

Model 230 Programmable Voltage Source

Instruction Manual



Contains Operating and Servicing Information

KEITHLEY

WARRANTY

Keithley Instruments, Inc. warrants this product to be free from defects in material and workmanship for a period of 1 year from date of shipment.

Keithley Instruments, Inc. warrants the following items for 90 days from the date of shipment: probes, cables, rechargeable batteries, diskettes, and documentation.

During the warranty period, we will, at our option, either repair or replace any product that proves to be defective.

To exercise this warranty, write or call your local Keithley representative, or contact Keithley headquarters in Cleveland, Ohio. You will be given prompt assistance and return instructions. Send the product, transportation prepaid, to the indicated service facility. Repairs will be made and the product returned, transportation prepaid. Repaired or replaced products are warranted for the balance of the original warranty period, or at least 90 days.

LIMITATION OF WARRANTY

This warranty does not apply to defects resulting from product modification without Keithley's express written consent, or misuse of any product or part. This warranty also does not apply to fuses, software, non-rechargeable batteries, damage from battery leakage, or problems arising from normal wear or failure to follow instructions.

THIS WARRANTY IS IN LIEU OF ALL OTHER WARRANTIES, EXPRESSED OR IMPLIED, INCLUDING ANY IMPLIED WARRANTY OF MERCHANTABILITY OR FITNESS FOR A PARTICULAR USE. THE REMEDIES PROVIDED HEREIN ARE BUYER'S SOLE AND EXCLUSIVE REMEDIES.

NEITHER KEITHLEY INSTRUMENTS, INC. NOR ANY OF ITS EMPLOYEES SHALL BE LIABLE FOR ANY DIRECT, INDIRECT, SPECIAL, INCIDENTAL OR CONSEQUENTIAL DAMAGES ARISING OUT OF THE USE OF ITS INSTRUMENTS AND SOFTWARE EVEN IF KEITHLEY INSTRUMENTS, INC., HAS BEEN ADVISED IN ADVANCE OF THE POSSIBILITY OF SUCH DAMAGES. SUCH EXCLUDED DAMAGES SHALL INCLUDE, BUT ARE NOT LIMITED TO: COSTS OF REMOVAL AND INSTALLATION, LOSSES SUSTAINED AS THE RESULT OF INJURY TO ANY PERSON, OR DAMAGE TO PROPERTY.

The logo for Keithley Instruments, featuring the word "KEITHLEY" in a bold, white, sans-serif font inside a black rectangular box.

Keithley Instruments, Inc. • 28775 Aurora Road • Cleveland, OH 44139 • 216-248-0400 • Fax: 216-248-6168 • <http://www.keithley.com>

CHINA:	Keithley Instruments China • Yuan Chen Xin Building, Room 705 • No. 12 Yumin Road, Dewai, Madian • Beijing, China 100029 • 8610-2022886 • Fax: 8610-2022892
FRANCE:	Keithley Instruments SARM • BP 60 • 3 allée des Garays • 91122 Palaiseau Cédex • 31-6-0115155 • Fax: 31-6-0117726
GERMANY:	Keithley Instruments GmbH • Landsberger Straße 65 • 82110 Germering • 49-89-849307-0 • Fax: 49-89-84930759
GREAT BRITAIN:	Keithley Instruments, Ltd. • The Minster • 58 Portman Road • Reading, Berkshire RG30 1EA • 44-01734-575666 • Fax: 44-01734-596469
ITALY:	Keithley Instruments SRL • Viale S. Gimignano 38 • 20146 Milano • 39-2-48303008 • Fax: 39-2-48302274
JAPAN:	Keithley KK • Aibido Bldg. • 7-20-2 Nishishinjuku • Shinjuku-ku, Tokyo 160 • 81-3-5389-1964 • Fax: 81-3-5389-2068
NETHERLANDS:	Keithley Instruments BV • Avelingen West 49 • 4202 MS Gorinchem • 31-(0)183-635333 • Fax: 31-(0)183-630821
SWITZERLAND:	Keithley Instruments SA • Kriesbachstrasse 4 • 8600 Dübendorf • 41-1-8219444 • Fax: 41-1-8203081
TAIWAN:	Keithley Instruments Taiwan • 1, Ming-Yu First Street • Hsinchu, Taiwan, R.O.C. • 886-35-778462 • Fax: 886-35-778455

Model 230 Programmable Voltage Source Instruction Manual

© 1992, Keithley Instruments, Inc.
Test Instrumentation Group
All rights reserved.
Cleveland, Ohio, U.S.A.
February 1992, First Printing
Document Number: 230-901-01 Rev. G

Safety Precautions

The following safety precautions should be observed before using this product and any associated instrumentation. Although some instruments and accessories would normally be used with non-hazardous voltages, there are situations where hazardous conditions may be present.

This product is intended for use by qualified personnel who recognize shock hazards and are familiar with the safety precautions required to avoid possible injury. Read the operating information carefully before using the product.

Exercise extreme caution when a shock hazard is present. Lethal voltage may be present on cable connector jacks or test fixtures. The American National Standards Institute (ANSI) states that a shock hazard exists when voltage levels greater than 30V RMS, 42.4V peak, or 60VDC are present. **A good safety practice is to expect that hazardous voltage is present in any unknown circuit before measuring.**

Before operating an instrument, make sure the line cord is connected to a properly grounded power receptacle. Inspect the connecting cables, test leads, and jumpers for possible wear, cracks, or breaks before each use.

For maximum safety, do not touch the product, test cables, or any other instruments while power is applied to the circuit under test. ALWAYS remove power from the entire test system and discharge any capacitors before: connecting or disconnecting cables or jumpers, installing or removing switching cards, or making internal changes, such as installing or removing jumpers.

Do not touch any object that could provide a current path to the common side of the circuit under test or power line (earth) ground. Always make measurements with dry hands while standing on a dry, insulated surface capable of withstanding the voltage being measured.

Do not exceed the maximum signal levels of the instruments and accessories, as defined in the specifications and operating information, and as shown on the instrument or test fixture rear panel, or switching card.

Do not connect switching cards directly to unlimited power circuits. They are intended to be used with impedance limited sources. NEVER connect switching cards directly to AC main. When connecting sources to switching cards, install protective devices to limit fault current and voltage to the card.

When fuses are used in a product, replace with same type and rating for continued protection against fire hazard.

Chassis connections must only be used as shield connections for measuring circuits, NOT as safety earth ground connections.

If you are using a test fixture, keep the lid closed while power is applied to the device under test. Safe operation requires the use of a lid interlock.

If a  screw is present on the test fixture, connect it to safety earth ground using #18 AWG or larger wire.

The  symbol on an instrument or accessory indicates that 1000V or more may be present on the terminals. Refer to the product manual for detailed operating information.

Instrumentation and accessories should not be connected to humans.

Maintenance should be performed by qualified service personnel. Before performing any maintenance, disconnect the line cord and all test cables.

SPECIFICATIONS

RANGE	MAXIMUM OUTPUT	ACCURACY (1 YEAR) 18°-28°C	STEP SIZE	TEMPERATURE COEFFICIENT/°C 0°-18°C & 28°-50°C
100 V	± 101.00 V	0.05 % + 50mV	50mV	0.005% + 0.5mV
10 V	± 19.995 V	0.05 % + 10mV	5mV	0.005% + 100 μV
1 V	± 1.9995 V	0.05 % + 1mV	500 μV	0.005% + 25 μV
100mV	± 199.9 mV	0.075% + 300 μV	50 μV	0.01 % + 25 μV

MAXIMUM CURRENT LIMIT: ±100mA (-0, +20%).

SELECTABLE CURRENT LIMIT: ±100mA (-0, +20%), ±20mA (-5, +20%), ±2mA (±20%) up to ±50V on output. At higher voltages subtract 15% from 2mA range lower limit.

LINE REGULATION: Less than 0.01% for AC power line changes within specified limits.

NOISE: (150μV + 50ppm range) p-p, 0.1Hz to 300Hz; 5mV p-p, 0.1Hz to 300kHz. Specification applies for local sensing only Typical.

RESPONSE TIME: Less than 3ms to within 0.1% of programmed change for Current Limit of at least 20mA.

TRANSIENT RECOVERY TIME: Less than 3ms to rated accuracy for Current Limit of at least 20mA.

OUTPUT IMPEDANCE:

SELECTED CURRENT LIMIT	OUTPUT IMPEDANCE
2mA	1mΩ + 10mH
20mA	1mΩ + 2mH
100mA	1mΩ + 1mH

SENSING: Rear panel switch selectable REMOTE and LOCAL SENSING.

REMOTE SENSING: Maximum lead drop: 0.5V. Maximum sense lead resistance: 5Ω. Specifications are per lead.

PROGRAM MEMORY: Number of Locations: 100. Range of Dwell Times: 3ms to 999.9s. Accuracy of dwell times: ±(0.05% + 200μs).

EXTERNAL TRIGGER: TTL-compatible EXTERNAL TRIGGER INPUT and OUTPUT.

OUTPUT CONNECTIONS: Five-way binding posts for OUTPUT, OUTPUT SENSE, COMMON, COMMON SENSE, CHASSIS and BNC (chassis isolated) connectors for EXTERNAL TRIGGER INPUT and OUTPUT. All connections on rear panel.

IEEE-488 BUS IMPLEMENTATION

Multiline Commands: DCL, LLO, SDC, GET, GTL, UNT, UNL, SPE, SPD, Uniline Commands: IFC, REN, EOI, SRQ, ATN.

Interface Functions: SH1, AH1, T6, TE0, L4, LE0, SR1, RL1, PP0, DC1, DT1, C0, E1.

Internal Programmable Parameters: DISPLAY MODE, OUTPUT, Prefix (Data Format), EOI, SRQ (including mask for over I-LIMIT), PROGRAM MODE, Range, Trigger Mode, Terminator Character, Inputs (SOURCE, I-LIMIT, DWELL TIME, 100-Point Memory Locations), Output Status, Digital Self Test.

Digital I/O Port: A separate I/O port consisting of four input and four output lines as well as common (IEEE-488) and +5VDC. Outputs will drive one TTL load. Inputs represent one TTL load. The 230 can be programmed to generate an "SRQ" upon *any* change in the four bit input data. Mating connector supplied.

GENERAL

DISPLAY: 0.5" LED digits, 4½-digit signed mantissa, 1-digit signed exponent.

SYSTEMS COMPATIBILITY: IEEE-488-1978.

OVER LIMIT INDICATION: "I-LIMIT" LED will blink.

SELF TEST: Digital RAM, ROM and front panel LEDs upon power ON.

WARMUP: 1 hour to rated accuracy.

POWER: 105-125 or 210-250VAC (internal switch selected), 50 or 60Hz, 60W maximum (80VA maximum). 90-105 or 180-210VAC operation available.

COOLING: Internal fan for forced air cooling.

ENVIRONMENTAL LIMITS: **Operating:** 0°-50°C; up to 35°C at 70% non-condensing relative humidity. **Storage:** -25° to 70°C.

DIMENSIONS, WEIGHT: 127mm high × 216mm wide × 359mm deep (5" × 8½" × 14⅞"). Net weight 9 lbs. 11 oz. (4.39kg).

MAXIMUM ALLOWABLE COMMON MODE VOLTAGE (OUTPUT or OUTPUT COMMON to CHASSIS): 250V rms, DC to 60 Hz.

ACCESSORIES AVAILABLE:

- Model 1019A: Universal Rack Mounting Kit
- Model 1019S: Universal Rack Mounting Kit (slides)
- Model 7008-3: IEEE-488 Cable (3 ft.)
- Model 7008-6: IEEE-488 Cable (6 ft.)

The following is further clarification of the Model 230 response time:

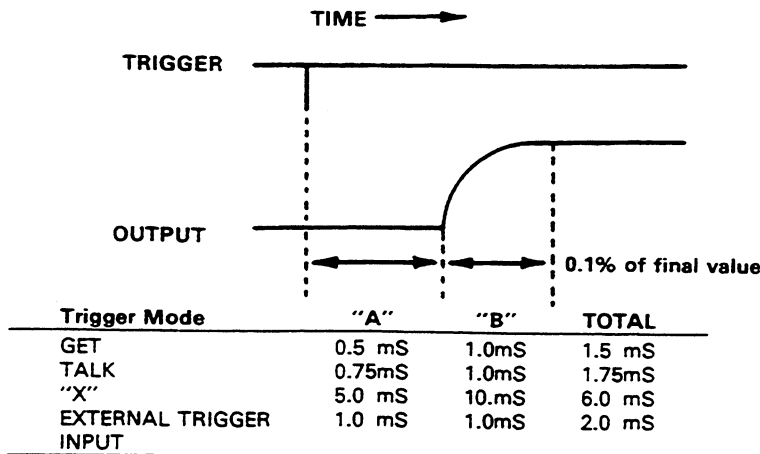

TABLE OF CONTENTS

Paragraph	Title	Page
SECTION 1-GENERAL INFORMATION		
1.1	Introduction	1-1
1.2	Features	1-1
1.3	Warranty Information	1-1
1.4	Manual Addenda	1-1
1.5	Safety Symbols and Terms	1-1
1.6	Unpacking and Inspection	1-1
1.7	Repackaging For Shipment	1-1
1.8	Specifications	1-1
1.9	Accessories	1-1
SECTION 2-OPERATION		
2.1	Introduction	2-1
2.2	Preparation For Use	2-1
2.2.1	Power-Up	2-1
2.2.2	Warm-Up	2-1
2.3	Operating Instructions	2-1
2.3.1	Environmental Conditions	2-1
2.3.2	Front Panel Control Descriptions	2-1
2.3.3	Rear Panel Descriptions	2-4
2.3.4	Output Connections	2-5
2.3.5	Inductive Loads	2-5
2.4	Operation Of The Model 230	2-5
2.4.1	Model 230 General Operating Procedure	2-5
2.4.2	Examples of Operation	2-6
2.5	Applications	2-10
2.5.1	Calibration	2-10
2.5.2	Active Loads	2-10
2.5.3	Measure Dielectric Absorption	2-10
2.5.4	Insulation Resistance	2-10
SECTION 3-PERFORMANCE VERIFICATION		
3.1	Introduction	3-1
3.2	Environmental Conditions	3-1
3.3	Recommended Test Equipment	3-1
3.4	Warm-Up	3-1
3.5	Performance Verification	3-1
3.5.1	DC Voltage Accuracy Check	3-1
SECTION 4-THEORY OF OPERATION		
4.1	Introduction	4-1
4.2	Block Diagrams	4-1
4.3	Power Supply	4-1
4.4	Analog Board	4-1
4.5	Digital Board (Microcomputer)	4-2
4.6	Display Circuit	4-4
SECTION 5-MAINTENANCE		
5.1	Introduction	5-1
5.2	Calibration	5-1
5.2.1	Recommended Test Equipment	5-1
5.2.2	Environmental Conditions	5-1
5.2.3	Warm-Up	5-1
5.2.4	Calibration Adjustments	5-1
5.3	Fuse Replacement	5-2
5.4	Line Voltage Selection	5-2

TABLE OF CONTENTS (CONT.)

Paragraph	Title	Page
5.5	Disassembly	5-3
5.6	Fan Filter Maintenance	5-3
5.7	Special Handling of Static Sensitive Devices	5-3
5.8	Troubleshooting	5-4
5.8.1	Digital Self Test	5-4
5.9	Current Limit Modification	5-4
 SECTION 6-REPLACEABLE PARTS		
6.1	Introduction	6-1
6.2	Parts List	6-1
6.3	Ordering Information	6-1
6.4	Factory Service	6-1
6.5	Schematic Diagrams and Component Location Drawings	6-1

LIST OF ILLUSTRATIONS

Figure	Title	Page
1-1	Instrument Packaging	1-2
2-1	Model 230 Front and Rear Panel Controls and Connections	2-2
2-2	Limiting Inductive Reaction Voltage	2-5
2-3	Square Wave Output Waveform	2-9
2-4	Using External Trigger	2-9
2-5	Using the Model 230 with a Power Amplifier	2-10
2-6	Model 230 Configured as an Active Load	2-10
2-7	Model 230 Recommended Operating Limits	2-10
2-8	Measuring High Resistance	2-11
2-9	Measuring Dielectric Absorption	2-11
3-1	Model 230 Performance Verification	3-1
4-1	Analog Circuitry Block Diagram	4-2
4-2	Digital Circuitry Block Diagram	4-3
4-3	Memory Map	4-4
5-1	Zero Span	5-2
5-2	100mV to 100V Calibration	5-2
5-3	Memory Chip Number Assignment	5-4
6-1	Model 230 Exploded View	6-2
6-2	Model 230 Fan Assembly	6-3
6-3	Display Board, Component Location Drawing, Dwg. No. 220-110	6-11
6-4	IEEE Interface Board, Component Location Drawing, Dwg. No. 220-130	6-12
6-5	Mother Board, Component Location Drawing, Dwg. No. 220-100	6-13
6-6	Analog Board, Component Location Drawing, Dwg. No. 230-120	617
6-7	Display Board, Schematic Diagram, Dwg. No. 220-116	6-21
6-8	Digital Circuitry, Schematic Diagram, Dwg. No. 220-106	6-23
6-9	Analog Board, Schematic Diagram, Dwg. No. 230-126	6-27
6-10	IEEE Interface Board, Schematic Diagram, Dwg. No. 220-136	6-31

LIST OF TABLES

Table	Title	Page
2-1	Line Voltage Setting	2-1
2-2	Parameter Limits	2-6
3-1	Recommended Test Equipment	3-1
5-1	Recommended Test Equipment	5-1
5-2	Fuse Replacement, 3AG Size	5-2
5-3	Fuse Replacement, 5mm Size	5-2
5-4	Line Voltage Selection	5-3
5-5	Model 230 Static Sensitive Devices	5-3
5-6	Power Supply Checks	5-4
5-7	Analog Board Checks	5-5
5-8	Digital Circuitry Checks	5-6
5-9	Display Board Checks	5-7
5-10	IEEE-488 Interface Board Checks	5-7
5-11	Resistor Specifications	5-7
5-12	Suggested Current Limit Modification	5-7
6-1	Index of Model 230 Schematic and Component Layouts	6-1
6-2	Mother Board 220-103, Parts List	6-4
6-3	Display Board 220-113, Parts List	6-6
6-4	Analog Board 230-123, Parts List	6-7
6-5	IEEE Interface Board, 220-133, Parts List	6-10

SECTION 1

GENERAL INFORMATION

1.1 INTRODUCTION

The Model 230 is a programmable voltage source with full range voltage from 199.95mV to 101V. The three selectable current limits allow the user to tailor the current limit from 2mA to 20mA to 100mA. The 100 memory locations allow up to 100 storage locations for programming source, I-limit and dwell time. The Model 230 can be used with any measurement system that uses the IEEE-488 interface bus. For detailed operating instructions of the Model 230 and the IEEE-488 bus, refer to the Model 220/230 Programming Manual.

1.2 FEATURES

The Model 230 includes the following features:

- 100 memory locations that are capable of storing up to 100 points of an output waveform.
- Programmable dwell time between the memory locations when used in the single or continuous program modes.
- Input and output connections for external triggering located on the rear panel.
- Selectable current limit allows user to tailor the current limit from 2mA, to 20mA to 100mA.
- 4 ½ digit display with appropriate exponent and decimal point.
- Data keyboard to enter data (source, I-limit, dwell time, etc.) into the buffer.
- OPERATE button that places the output in an inactive state until programmed into operate.
- IEEE-488 interface bus operation is standard. This enables the user to immediately incorporate the Model 230 into a measurement system that uses programmed control through the IEEE-488 bus.

1.3 WARRANTY INFORMATION

Warranty information is provided on the inside front cover of this manual. If there is a need to exercise the warranty, contact the Keithley representative in your area to determine the proper action to be taken. Keithley maintains complete repair and calibration facilities in the United States, West Germany, Great Britain, France, the Netherlands, Switzerland and Austria. Information concerning the application, operation or service of your instrument may be directed to the applications engineer at any of the above locations. Check the inside front cover of this manual for addresses.

1.4 MANUAL ADDENDA

Improvements or changes to this manual will be explained on a addendum included with this manual.

1.5 SAFETY SYMBOLS AND TERMS

Safety symbols used in this manual are as follows:

The symbol  on the instrument denotes that the user should refer to the operating instructions.

The symbol  on the instrument denotes that 1000V or more may be present on the terminal(s).

The **WARNING** used in this manual explains dangers that could result in personal injury or death.

The **CAUTION** used in this manual explains hazards that could damage the instrument.

1.6 UNPACKING AND INSPECTION

The Model 230 is inspected both mechanically and electrically before shipment. Upon receiving the Model 230 unpack all items from the shipping container and check for any obvious damage that may have occurred during transit. Report any damage to the shipping agent. Retain and use the original packaging materials if reshipment is necessary. The following items are shipped with all Model 230 orders:

- Model 230 Programmable Voltage Source
- Model 230 Instruction Manual
- Model 220/230 Programming Manual
- Optional accessories per request.

If an additional instruction manual is required, order the manual package (Keithley Part Number 230-901-00). The manual package includes an instruction manual and all pertinent addenda.

1.7 REPACKAGING FOR SHIPMENT

The Model 230 should be packed in its original carton. Before packaging, wrap the instrument in plastic. After it is placed in the box, surround the instrument with styrofoam packaging material.

If the Model 230 is to be returned to Keithley Instruments for calibration or repair, include the following:

- **ATTENTION REPAIR DEPARTMENT** on the address label.
- Warranty status of the instrument.
- Completed service form.

1.8 SPECIFICATIONS

For Model 230 detailed specifications, refer to the specifications that precede this section.

1.9 ACCESSORIES

The following optional accessories are available from Keithley Instruments to enhance the capabilities of the Model 230.

Model 1019A Universal Rack Mounting Kit-The Model 1019A Universal Rack Mounting Kit can accommodate one or two Model 230's. The dimensions are 133mm × 483mm (5¼" × 19").

Model 1019S Slide Rack Mounting Kit-Enables one or two half rack size instruments to be rack mounted with the added feature of sliding the instrument(s) for easy access. The dimensions are 133mm × 483mm (5¼" × 19").

Model 7008-3 IEEE-488 Cable-The Model 7008-3 is a three foot (1 meter) IEEE-488 cable. The cable has 24 stranded wire conductors and is terminated with IEEE-488 standard connectors.

Model 7008-6 IEEE-488 Cable-The Model 7008-6 is a six foot (2 meter) IEEE-488 cable. The cable has 24 stranded wire conductors and is terminated with IEEE-488 standard connectors.

Model 7010 Cable Adapter-The Model 7010 is a Hewlett-Packard IEEE cable adapter. The adapter extends the IEEE-488 connector by one connector width.

SECTION 2 OPERATION

2.1 INTRODUCTION

This section includes operating instructions for basic use of the Model 230. Instructions such as: front and rear panel controls, examples of how to use the Model 230 and applications of the Model 230 are covered in this section. For Model 230 front and rear panel illustrations refer to Figure 2-1.

2.2 PREPARATION FOR USE

2.2.1 Power-Up

Plug the Model 230 into the proper power receptacle (see Table 2-1). For fuse replacement or line switch (S102) setting refer to the maintenance section.

WARNING

Ground the instrument through a properly earth grounded receptacle before operation. Failure to ground the instrument can result in severe injury or death in the event of short circuit or malfunction.

Table 2-1. Line Voltage Setting

Input Voltage	Switch Setting S102	Fuse (F101)
105V-125V	115VAC	1/2A, 250V, 3AG
210V-250V	230VAC	1/4A, 250V, 3AG
90V-110V*	115VAC	1/2A, 250V, 3AG
180V-220V*	230VAC	1/4A, 250V, 3AG

*For instruments equipped with low voltage transformer TR-187.

Immediately after turning on the Model 230 via the power switch, the following display message will be indicated.

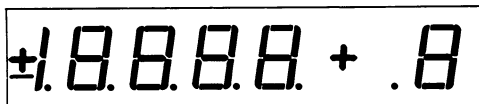

1. This is a display test, the operator can note inoperative display segments by comparing the Model 230's display with the figure above.
2. In addition, the push button and IEEE-488 bus (TALK, LISTEN and REMOTE) indicators will light. All indicators will light simultaneously if operating correctly.

After the display test is complete the Model 230 will display the software revision level for approximately one second.

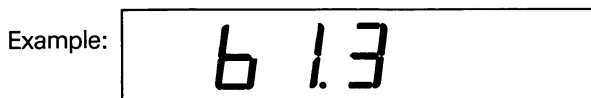

After the software revision level is displayed, the Model 230 will display the primary address of the instrument for approximately one second. The primary address of the Model 230 is factory set at 13.

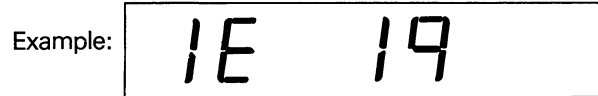

The Model 230 also performs a digital self test of the RAM circuitry and a cyclic redundancy check (CRC) of the ROM circuitry. If the self test or CRC reveals a problem with the RAM or ROM circuitry the Model 230 will display a diagnostic number. This number and its meaning is discussed in detail in Section 5.

2.2.2 Warm-Up

To achieve rated accuracy the Model 230 requires one hour for warm-up.

2.3 OPERATING INSTRUCTIONS

2.3.1 Environmental Conditions

Operation should be at an ambient temperature within the range of 0°C to 50°C, up to 35°C at 80% noncondensing relative humidity. Environmental conditions for storage are -25°C to +70°C

2.3.2 Front Panel Control Descriptions

Power ON/OFF switch operates on the push-push principle. Depressing this button turns the instrument on. Pushing the button a second time (releasing) turns the instrument off.

Display—There are four operating functions in the display group. Each button selects its function for display. They are described as follows:

SOURCE button selects the source data for display. The range of the available full scale source voltage is 199.95mV to 101.00V. The source voltage is displayed as a four and a half digit number with a single digit exponent. The least significant digit of the 4½ digit display is truncated to zero or a five when the ENTER button is pressed. When a 1, 2, 3 or 4 is entered on the display as the least significant digit, it is truncated to a zero when the ENTER button is pressed. When a 6, 7, 8 or 9 is entered on the display as the least significant digit, it is truncated to a five when the ENTER button is pressed.

During the entry of source data onto the display (c segment cursor is flashing) pressing the SOURCE button reverts the display to the previous source data. A different source voltage can be programmed for each of the 100 memory locations.

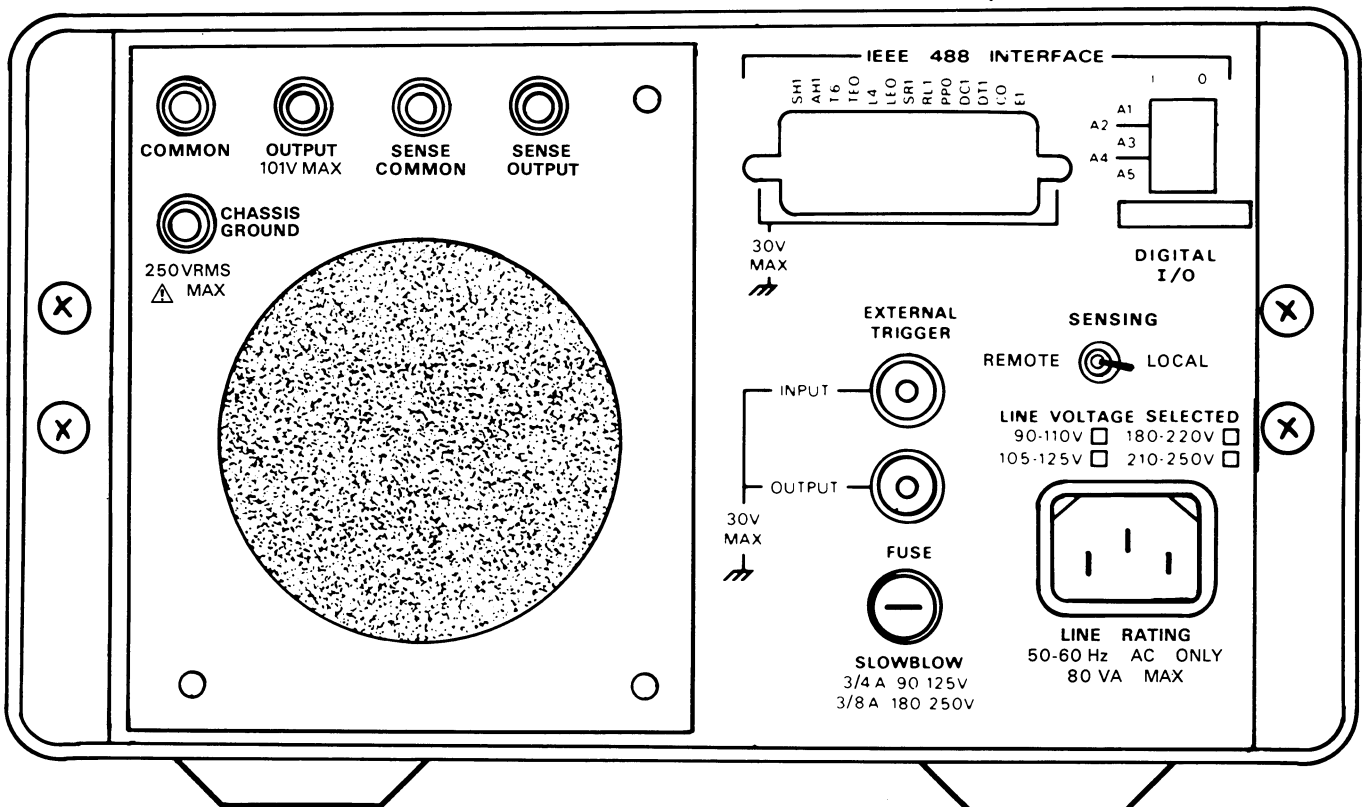
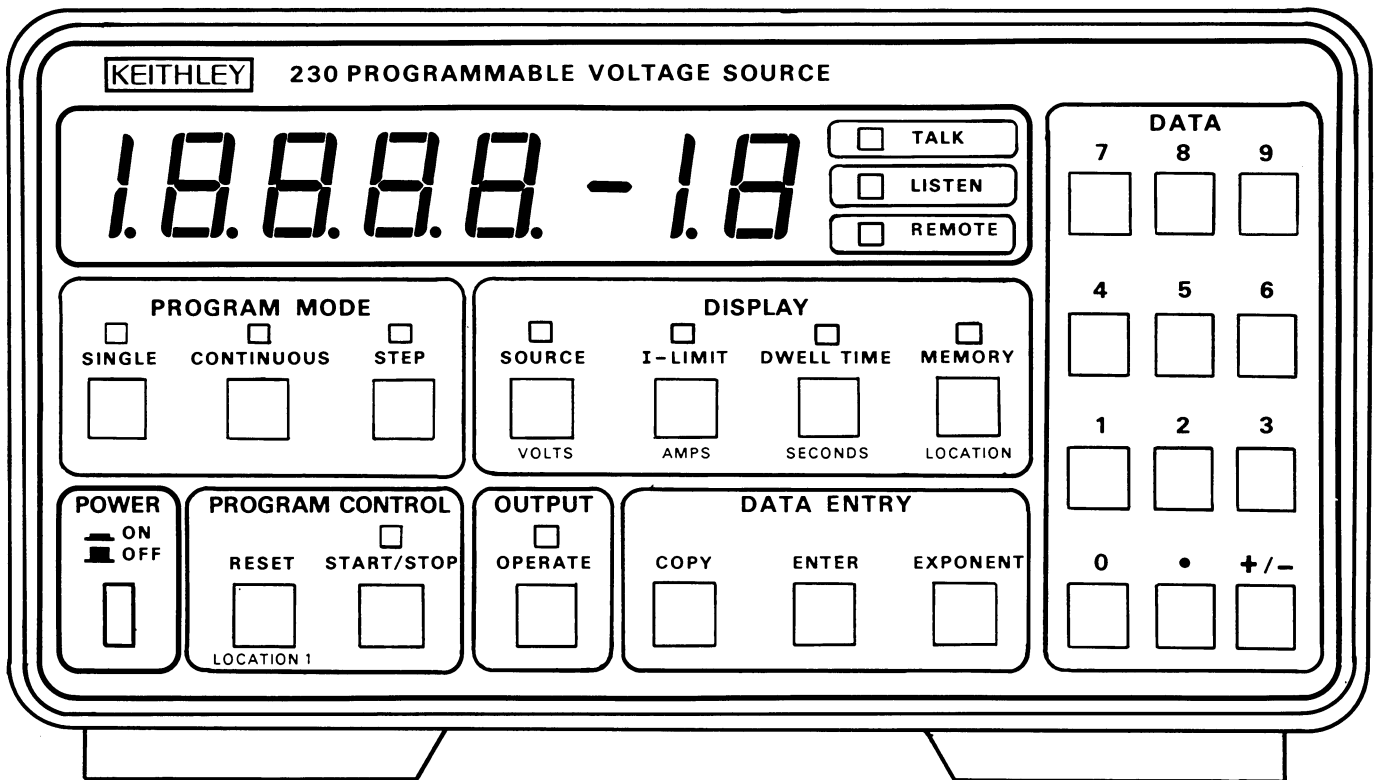

Figure 2-1. Model 230 Front and Rear Panel Controls and Connections

I-LIMIT button selects the current compliance (2mA, 20mA or 100mA) limit for display. The current compliance limit is displayed as a three digit number with a single digit exponent. The single digit exponent is fixed at a negative 3 which depicts mA. The three digit number is right justified when the ENTER button is pressed. There are three levels of selectable current compliance. The levels are 2mA, 20mA and 100mA. Programming a current compliance limit other than 2mA, 20mA or 100mA will result in a displayed information message when the ENTER button is pressed. For example: attempt to program the Model 230 for a 50mA current limit by pressing the following buttons.

- A. I-LIMIT (Selects the current limit function for display.)
- B. 5, 0, (Enters 50mA on the display.)
- C. ENTER (Attempts to enter the 50mA data into the present memory location.)

After ENTER is pressed the following is displayed for approximately one second.



After the E100 is displayed, the following is displayed for approximately one second:



The previous two display messages remind the user that only 2mA, 20mA or 100mA can be programmed the current compliance limit. After the two displays, the Model 230 reverts to the previously displayed current limit. That is, if the current limit was programmed for 20mA, then that is the condition the Model 230 reverts to after the two display messages.

During the entry of current compliance limit data onto the display (c segment cursor is flashing) pressing the I-LIMIT button reverts the display to the previous I-limit value. A different current compliance limit can be programmed to each of the 100 memory locations.

NOTE

The I-limit can be modified to accommodate other current compliance limit needs. Refer to paragraph 5.9 for information concerning current limit modification.

DWELL TIME button selects the dwell time mode for display. Dwell time is the interval time the Model 230 spends on a specific memory location. The range of the dwell time is 3msec to 999.9sec in 1msec increments. The dwell time is displayed as a 4½ digit number with a single digit exponent. After the data is entered on the display and the ENTER button is pressed the exponent is displayed as a 0 or a 3 depending on the data entered. An entry of zero for the dwell, in any memory location except the first will be interpreted as a reset in the step or continuous program modes to permit short cycling of the programmed memory locations. It will be interpreted as a stop in

the single program mode. The dwell time accuracy listed in the specifications requires that the IEEE-488 bus be inactive.

During the entry of dwell time data onto the display, (c segment cursor is flashing) pressing the DWELL TIME button reverts the display to the previous dwell time data. A different dwell time can be programmed for each of the 100 memory locations.

MEMORY button selects the present memory location number for display. There are 100 available memory locations. They start at memory location 1 and range up to memory location 100. The memory location is displayed as a three digit number. The three digit number is right justified when a one or two digit number is entered onto the display and the ENTER Button is pressed. Upon power-up, or upon the actuation of the RESET button, the Model 230 selects memory location 1 as the present memory location.

Each memory location contains the source current data, I-limit data, dwell time data and the number of the memory location. To display any of these parameters contained in a particular memory location simply press the appropriate button (e.g. SOURCE, I-LIMIT, DWELL TIME or MEMORY). The data for each of these parameters can vary for each memory location. This means the Model 230 can store up to 100 different values of source current, compliance voltage and dwell time.

During the entry of memory location data onto the display (c segment cursor is flashing) pressing the MEMORY button reverts the display to the previously displayed memory location.

NOTE

The contents of all the memory locations is lost when the power to the Model 230 is turned off.

Data Entry—The data entry group consists of the COPY, ENTER and EXPONENT buttons. The function of these buttons is described as follows:

EXPONENT button allows entry of exponent data onto the display and is active only in the source and dwell time display modes. Once the single digit exponent has been entered onto the display and the ENTER button is pressed, the Model 230 places the data and the exponent into the proper notation. For example: If 520.0-7 is entered onto the display, it is displayed as 52.00-6 after the ENTER button is pressed. The only time the exponent is positive is when it is zero.

ENTER button loads the displayed data into the present memory location.

COPY button duplicates the source, V-limit and dwell time data from one memory location into the next memory location. The COPY button is active only in the Memory Display Mode. For an example of how to use the COPY button refer to example 5.

OUTPUT button is an alternative action control which places the instrument in the displayed output mode. In the operate mode, the OUTPUT LED is turned on and the source data in the present memory location is present at the output connector on the rear panel. When the instrument is not in the operate mode (OUTPUT LED is off), the output is programmed to 00.00-3 volts.

Program Mode—The program mode group consists of the SINGLE, CONTINUOUS and STEP buttons. These three buttons select the possible modes of scanning the programmed memory locations. The buttons are described as follows:

STEP button selects the step program mode. The step program mode allows the user to manually step through the programmed memory locations using the START/STOP button. Pressing the START/STOP button when in the step program mode advances the instrument to the next programmed memory location. Also, the START/STOP LED turns on for the programmed dwell time. When the Model 230 is in the step program mode the STEP LED is turned on.

SINGLE button selects the single program mode and turns on the SINGLE LED. The single program mode cycles through all of the programmed memory locations one time upon the actuation of the START/STOP button. Upon the actuation of the START/STOP button the START/STOP LED turns on and the Model 230 advances to the next programmed memory location. The Model 230 remains at this memory location for the programmed dwell time. At the end of the dwell time the Model 230 advances to the next programmed memory location and remains there for the programmed dwell time. This cycle repeats itself until the end of the dwell time of the last programmed memory location. The last programmed memory location being the one prior to the one having the zero dwell time. At this point the START/STOP LED turns off and the single program mode is stopped.

CONTINUOUS button selects the continuous program mode and turns on the CONTINUOUS LED. The continuous program mode cycles through the programmed memory locations continuously upon actuation of the START/STOP button. Upon the actuation of the START/STOP button, the START/STOP LED turns on and the Model 230 advances to the next programmed memory location. The Model 230 remains at this memory location for the programmed dwell time. At the end of the dwell time the Model 230 advances to the next programmed memory location and remains there for the programmed dwell time. This cycle repeats itself until the end of the dwell time of the last programmed memory location. The last programmed memory location being the one prior to the one having the zero dwell time. At this point the Model 230 reverts to memory location 1 and continues the cycle. The continuous program mode can be stopped by pressing the START/STOP button. Pressing the START/STOP button turns off the START/STOP LED and stops the continuous program mode at the presently displayed memory location.

Program Control—The program control group consist of

the RESET and START/STOP buttons. These two buttons control the use of the single continuous and step program modes. The two buttons are described as follows:

RESET button is a momentary control that sets the presently displayed memory location to memory location 1. Pressing the RESET button, when in the operate mode, sets the output to the source value that is in memory location 1. Pressing the RESET button during the single or continuous program mode returns the instrument to memory location 2 and then continues the program mode cycle. Pressing the RESET button during the entry of data onto the display (C segment cursor is flashing) sets the display back to the previously displayed data. Once the data is entered onto the display and the ENTER button is pressed, pressing the RESET button reverts the instrument to the conditions of memory location 1.

START/STOP button is an alternate action control that serves two functions. The two functions are described as follows:

1. When the START/STOP button is pressed the START/STOP LED turns on and the selected program mode (step, single or continuous) is initiated.
2. When the START/STOP button is pressed a second time the START/STOP LED turns off and the action of the selected program mode is stopped.

NOTE

When the instrument is in the standby mode (OUTPUT LED is off) and either the single or continuous program mode, the START/STOP button continues to control the buffer with no output present from the Model 230. In the step mode, the START/STOP LED turns on for the duration of the programmed dwell time.

Data Group—This 12 button key-pad allows entry of numerical data from 0 to 9 along with decimal point and polarity onto the display.

TALK, LISTEN and REMOTE LEDs identify the present status of the IEEE-488 bus. For more information concerning the Model 230 and the IEEE bus refer to the Model 220/230 Programming Manual.

2.3.3 Rear Panel Description

OUTPUT connector is a five way binding post connector.

OUTPUT SENSE terminal can be connected either to the output terminal or to the remote load via the REMOTE/LOCAL switch to compensate for IR lead drop for optimum load regulation.

OUTPUT COMMON terminal provides easy access to output common.

SENSE COMMON terminal can be connected either to common or to the remote load common via the REMOTE/LOCAL switch to compensate for IR lead drop for optimum load regulation.

CHASSIS GROUND provides a convenient connection to chassis common (earth ground via the AC power line).

REMOTE/LOCAL SENSING switch configures the Model 230 for either remote sensing or local sensing. When a load is connected to the Model 230, there is an IR lead drop between the load and the Model 230. If the IR drop is too large to be tolerated, the Model 230 can be configured for remote sensing. Remote sensing eliminates the IR lead drop by maintaining regulation at the load instead of maintaining regulation at the output terminals of the Model 230.

When using remote sensing the output sense terminal and common sense terminals must be connected to output and common terminals respectively at the load.

CAUTION

Take care to connect the sense terminals to the load with the proper polarity. Improper polarity will result in possible damage to the instrument.

IEEE-488 INTERFACE connector provides IEEE-488 bus connection to the Model 230. The connector mates with the Model 7008-3 or Model 7008-6 IEEE-488 cable.*

PRIMARY ADDRESS switches are used to program the primary address for IEEE-488 bus operation.*

DIGITAL I/O PORT consists of four input and four output lines as well as IEEE-488 common and +5VDC. The outputs will drive one TTL load. The inputs represent one TTL load. The instrument can be programmed to generate an SRQ upon any change in the four bit input data.*

EXTERNAL TRIGGER INPUT initiates the selected program mode in the same manner as the START/STOP button upon receiving a TTL level, negative transition with a minimum pulse width of 10 μ sec.

EXTERNAL TRIGGER OUTPUT provides a TTL level negative transition output pulse greater than or equal to 10 μ sec upon the completion of the programmed dwell time.

The line power **FUSE** is rated as shown in Table 5-2 and 5-3.

The **LINE PLUG** mates with a three wire line cord which provides connections to the line voltage.

* For more information concerning the IEEE-488 connector, digital I/O port and primary address switches, refer to the Model 220/230 Programming Manual.

2.3.4 Output Connections

The maximum common mode voltage from output or output common to chassis common is 250V rms from DC to 60Hz.

CAUTION

Do not exceed the maximum allowable common mode voltage from output or output common to chassis common. Instrument damage may result.

2.3.5 Inductive Loads

In general, the output loads connected to the Model 230 should be resistive. However, a small amount of inductance in the load can be tolerated but only if the inductive reaction voltage ($L \frac{di}{dt}$) is limited to less than 101V. Refer to Figure 2-2 for a suggested method of limiting the inductive reaction voltage.

CAUTION

If the output load connected to the Model 230 is inductive, limit the inductive reaction voltage to less than 101V. Otherwise instrument damage may occur.

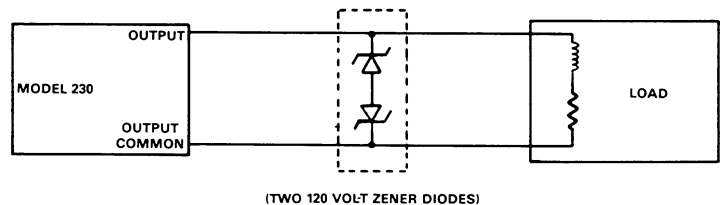

Figure 2-2. Limiting Inductive Reaction Voltage

2.4 OPERATION OF THE MODEL 230

The Model 230 has several different operating parameters. These parameters (step, single, continuous, source, V-limit, dwell time, etc) are to be programmed using the following general procedure. Several examples of exact programming are given after the general procedure.

2.4.1 Model 230 General Operating Procedure

1. Turn on the Model 230 and allow one hour for warm up.
2. Select memory location.
 - A. Press MEMORY.
 - B. Press the number(s) of the desired memory location (1 to 100).

NOTE

Upon power up or upon actuation of the RESET button the Model 230 is set to memory location 1.

- C. Press ENTER.
3. Program the desired source voltage.
 - A. Press SOURCE.
 - B. Press the number(s) of the desired source voltage. (00.00mV to 101.00V).

NOTE

Upon power-up the source voltage is set to 00.00-3.

- C. Press ENTER.
- 4. Program the appropriate I-limit.
 - A. Press I-LIMIT.
 - B. Press the number(s) of the appropriate compliance current limit (2mA, 20mA or 100mA).

NOTE

Upon power-up the I-limit is set to 2mA.

- C. Press ENTER.
- 5. Program the desired dwell time.
 - A. Press DWELL TIME.
 - B. Press the number(s) of the appropriate dwell time. (3msec to 999.9sec).

NOTE

Upon power-up the dwell time of memory location 1 is set to 3.000-3 seconds.

- 6. Select the desired program mode by pressing the STEP, SINGLE or CONTINUOUS button.

NOTE

Upon power-up the Model 230 selects the step program mode.

- 7. Connect appropriate load.

NOTE

The output load must be noninductive. A small amount of inductance in the load can be tolerated if the inductive reaction voltage ($L \frac{di}{dt}$) is limited to less than 101V. Refer to paragraph 2.3.5.

- 8. Program the output to the operate mode by pressing the OUTPUT button.
- 9. Select the program control by pressing the START/STOP button.

NOTE

Generally, the program mode (step, single and continuous) and the START/STOP button are used when multiple memory locations have been programmed.

2.4.2 Examples of Operation

The following examples describe several different operating levels and conditions.

Example 1 Error Message—The Model 220 will display an error message if it is programmed into a parameter value that is outside of the range of the instrument. Table 2-2 lists the conditions that cause an error message. For example, program the Model 230 for memory location 102.

- 1. Press MEMORY.
- 2. Press 1, 0, 2.
- 3. Press ENTER.

After the ENTER button is pressed, the Model 230 displays the following for approximately one second. Then, the Model 230 returns to the previous display of the memory location.

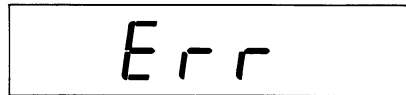

Table 2-2. Parameter Limits

Parameter Limits

Source	Greater than 101V.*
I-limit	See paragraph 2.3.2 (Display group, I-limit.)
Dwell Time	Less than 3msec, greater than 999.9 seconds.
Memory	Greater than 100 or an entry of 000.

*The Model 230 will not accept entries which require a resolution of less than 10µV.

Example 2—In this example the Model 230 will be programmed to output a voltage of 10V with a 20mA current compliance.

Required Output: 10V with 20mA compliance.

Use the following procedure to program the Model 230 to output the preceding parameters.

- 1. Select memory location, if memory location 1 is not desired.
- 2. Press SOURCE, 1, 0, EXPONENT, 0, ENTER. (Programs a source value of 10V.)
- 3. Press I-LIMIT, 2, 0, ENTER. (Programs 20mA current compliance.)
- 4. Connect load.
- 5. Press OPERATE.

NOTE

If the ENTER button is not pressed in the sequence indicated, the display data will not be programmed into the appropriate memory location.

Upon actuation of the OUTPUT button the Model 230 outputs 10V with a 20mA current compliance. At this point, the Model 230 is displaying the current compliance; to display the source voltage press SOURCE. At the end of this example press OUTPUT to place the Model 230 into the standby mode (OPERATE LED turned off.)

Example 3—In some applications of the Model 230 it may be advantageous to have multiple levels of voltage and current compliance. With the Model 230's 100 memory locations it is possible to have up to 100 different voltage levels. For this example the Model 230 will be programmed to output three separate voltage levels, three separate current

compliances, three separate dwell times and three separate memory locations. The three memory locations will be programmed in the step program mode.

Required Output: 100mV source, 2mA I-limit, one second dwell time, memory location 1.

1V source, 20mA I-limit, two second dwell time, memory location 2.

10V source, 100mA I-limit, three second dwell time, memory location 3.

1. Press MEMORY, 1, ENTER. (Selects memory location 1.)
2. Press SOURCE, 1, 0, 0, EXPONENT +/-, 3 ENTER. (Programs source of memory location 1 to 100mV.)
3. Press I-LIMIT, 2, ENTER. (Programs I-limit of memory location 1 to 2mA.)
4. Press DWELL TIME, 1, EXPONENT, 0, ENTER. (Programs dwell time of memory location 1 to one second.)
5. Press MEMORY, 2, ENTER. (Selects memory location #2.)
6. Press SOURCE, 1, EXPONENT, 0, ENTER. (Programs source of memory location 2 to 1V.)
7. Press I-LIMIT, 2, 0, ENTER. (Programs I-limit of memory location 2 to 20mA.)
8. Press DWELL TIME, 2, EXPONENT, 0, ENTER. (Programs dwell time of memory location 2 to two seconds.)
9. Press MEMORY, 3, ENTER. (Selects memory location 3.)
10. Press SOURCE, 1, 0, EXPONENT, 0, ENTER. (Programs source of memory location 3 to 10V.)
11. Press I-LIMIT, 1, 0, 0, ENTER. (Programs I-limit of memory location 3 to 100mA.)
12. Press DWELL TIME, 3, EXPONENT, 0, ENTER. (Programs dwell time of memory location 3 to three seconds.)
13. Press STEP. (Selects the step program mode.)

After completing step 13 the Model 230 is programmed into the parameters stated. To display any of the stated parameters, select the memory location of the desired parameter and then press the appropriate parameter button (SOURCE, I-LIMIT, DWELL TIME or MEMORY.)

To output any of the three source values, select the desired source value's memory location, press the SOURCE and OUTPUT button. The reason for pressing the SOURCE button is to display the source value. It is not absolutely necessary to output the source.

To advance to the next memory location press the START/STOP button. When the START/STOP button is pressed the Model 230 advances to the next memory location and turns on the START/STOP LED for the duration of the programmed dwell time.

Example 4—In this example the Model 230 will be programmed to output five separate voltage levels, five separate current compliances, five separate dwell times and five separate memory locations.

Required Output: 125mV source, 2mA I-limit, 0.5 second dwell time, memory location 1.

250mV source, 2mA I-limit, 1 second dwell time, memory location 2.

500mV source, 20mA I-limit, 1.5 second dwell time, memory location 3.

1V source, 20mA I-limit, 2 second dwell time, memory location 4.

2V source, 100mA I-limit, 2.5 second dwell time, memory location 5.

1. Press MEMORY, 1, ENTER. (Selects memory location 1.)
2. Press SOURCE, 1, 2, 5, EXPONENT, 3, ENTER. (Programs source of memory location 1 to 125mV.)
3. Press I-LIMIT, 2, ENTER. (Programs I-limit of memory location 1 to 2mA.)
4. Press DWELL TIME, 5, 0, 0, EXPONENT, +/-, 3, ENTER. (Programs dwell time of memory location 1 to 0.5 seconds.)
5. Press MEMORY, 2, ENTER. (Selects memory location 2.)
6. Press SOURCE, 2, 5, 0, EXPONENT, +/-, 3, ENTER. (Programs source of memory location 2 to 250mV.)
7. Press I-LIMIT, 2, ENTER. (Programs I-limit memory location 2 to 2mA.)
8. Press DWELL TIME, 2, EXPONENT, 0, ENTER. (Programs dwell time of memory location 2 to 1 second.)
9. Press MEMORY, 3, ENTER. (Selects memory location 3.)
10. Press SOURCE, 5, 0, 0, EXPONENT, +/-, 3, ENTER. (Programs source of memory location 3 to 500mV.)
11. Press I-LIMIT, 2, 0, ENTER. (Programs I-limit of memory location 3 to 20mA.)
12. Press DWELL TIME, 2, 0, ENTER. (Programs I-limit of memory location 3 to 20mA.)
13. Press MEMORY, 4, ENTER. (Selects memory location 4.)
14. Press SOURCE, 1, EXPONENT, 0, ENTER. (Programs source of memory location 4 to 1V.)
15. Press I-LIMIT, 2, 0, ENTER. (Programs I-limit of memory location 4 to 20mA.)
16. Press DWELL TIME, 2, EXPONENT, 0, ENTER. (Programs dwell time of memory location 4 to 2 seconds.)
17. Press MEMORY, 5, ENTER. (Selects memory location 5.)
18. Press SOURCE, 2, EXPONENT, 0, ENTER. (Programs source of memory location 5 to 2V.)
19. Press I-LIMIT, 1, 0, 0, ENTER. (Programs I-limit of memory location 5 to 100mA.)
20. Press DWELL TIME, 2, ., 5, EXPONENT, ENTER. (Programs dwell time of memory location 5 to 2.5 seconds.)

After completing step 20 the Model 230 is programmed into the parameters stated. To display any of the stated parameters, select the memory location of the desired parameters and then press the appropriate parameter button (SOURCE, I-LIMIT, DWELL TIME, or MEMORY). To output any of the source values select the desired source value's memory location and press the OUTPUT button.

To scan the five memory locations use the following procedure:

1. Select the program mode of scanning. (Select SINGLE, CONTINUOUS or STEP.)
2. Select desired display mode. (Source, I-limit, dwell time or memory.)
3. Press the START/STOP button.

In the step program mode the user can manually step through the programmed memory locations one at a time. Each time it is desired to advance to the next memory location the user presses the START/STOP button. The START/STOP LED turns on for the duration of the programmed dwell time. When the last programmed memory location is selected (memory location 5 in this example) pressing the START/STOP button reverts the instrument to memory location 1.

In the single program mode the Model 230 cycles through all of the programmed memory locations one time. To start the single program mode press the START/STOP button. Once the single program mode is activated, the Model 230 starts from the next programmed memory location and advances to each programmed memory location. The instrument remains at each memory location for the programmed dwell time and then advances to the next programmed memory location. After the dwell time of the last programmed memory location the START/STOP LED turns off and the single program mode is ended. The last programmed location being the one prior to the one having the zero dwell time. The Model 230 remains at the last programmed memory location until either power is turned off, RESET is pressed, memory location is changed or the single or continuous program modes are activated.

NOTE

An entry of zero for the dwell time in any memory location except the first will be interpreted as a reset in the step and continuous program modes to permit short cycling of the programmed memory locations. It will be interpreted as a stop in the single program mode.

In the continuous program mode the Model 230 cycles through all of the programmed memory locations continuously. To start the continuous program mode press the START/STOP button. To stop the continuous program mode press the START/STOP button a second time. When the START/STOP button is pressed the second time the continuous program mode is stopped at the present memory location. Once the continuous program mode is activated, the Model 230 advances to the next memory location. The instrument remains at the memory location for the programmed dwell time (dwell time can vary with each memory location) and then advances to the next memory location. The cycle continues up to and including the last programmed memory location and then reverts to memory location 1. At this point the cycle starts over again and keeps on repeating until the START/STOP button is pressed, power to the instrument is turned off or the single or step program modes are selected.

Example 5—In this example the COPY button will be used to duplicate the data of memory location 1 into memory locations 2, 3, 4 and 5. The COPY button function, when used in the memory display mode, duplicates the source, I-limit and dwell time data of one memory location into the next memory location. Program the following parameters into memory location 1 and use the procedure to duplicate these parameters into memory locations 2, 3, 4 and 5.

Required Parameters: 15.00V source, 20mA I-limit,
525msec dwell time.

1. Press MEMORY, 1, ENTER. (Selects memory location 1.)
2. Press SOURCE, 1, 5, EXPONENT, 0, ENTER. (Programs source of memory location 1 to 15V.)
3. Press I-LIMIT, 2, 0, ENTER. (Programs I-limit of memory location 1 to 20mA.)
4. Press DWELL TIME, 5, 2, 5, EXPONENT, 3, ENTER. (Programs dwell time of memory location 1 to 525msec.)
5. Press MEMORY, COPY, COPY, COPY, COPY. (Selects memory display mode and duplicates the data in memory location 1 into memory location 2, 3, 4 and 5.)

The parameters that were specified were programmed into the Model 230 by steps 1 through 4. The parameters of memory location 1 were duplicated into memory locations 2, 3, 4 and 5 by completing step 5. To verify that the data was duplicated into other memory locations, select each memory location and select each parameter for each memory location. For example: To verify that 15V was duplicated into memory location 3 do the following.

1. Press MEMORY, 3, ENTER. (Selects memory location 3.)
2. Press SOURCE. (Displays source data memory location 3.)

The COPY button function is useful in a situation where the user needs several voltage source values but with the same current compliance and dwell time. In this case the user could program the dwell time and current compliance for one memory location and duplicate them into the desired memory locations. At this point the user can program the individual voltage source values in the desired memory locations. Use of the COPY button in this case can save the user several steps of programming.

Example 6 Fabricating Output Waveforms—The Model 230 is capable of fabricating output waveforms. With the 100 internal memory locations the Model 230 can fabricate waveforms with up to 100 individual steps. The following procedure is an example of programming the Model 230 to output a square wave of +5V to 0V at a frequency of 100Hz.

Required Output: +5V to 0V square wave at 100Hz with an I-limit of 100mA.

NOTE

Cycle power to the instrument before starting this example to avoid confusion of previously programmed memory locations.

1. Press MEMORY, 1, ENTER. (Selects memory location 1.)
2. Press SOURCE, 5, EXPONENT, 0, ENTER. (Programs source of memory location 1 to 5V.)
3. Press I-LIMIT, 1, 0, 0, ENTER. (Programs I-limit of memory location 1 to 100mA.)
4. Press DWELL TIME, 5, EXPONENT, 3, ENTER. (Programs dwell time of memory location 1 to 5msec.)
5. Press MEMORY, 2, ENTER. (Selects memory location 2.)
6. Press SOURCE, 0, EXPONENT, 0, ENTER. (Programs source of memory location 2 to 0V.)
7. Press I-LIMIT, 1, 0, 0, ENTER. (Programs I-limit of memory location 2 to 100mA.)
8. Press DWELL TIME, 5, EXPONENT, +/-, 3, ENTER. (Programs dwell time of memory location 2 for 5msec.)
9. Press CONTINUOUS, OPERATE, START/STOP. (Selects the continuous program mode, outputs the source voltage and starts the continuous program mode which fabricates the +5V to 0V 100Hz waveform.)

NOTE

When fabricating output waveforms observe the response time specifications of the Model 230. Also, consider the effect of load impedance on the waveform to be fabricated.

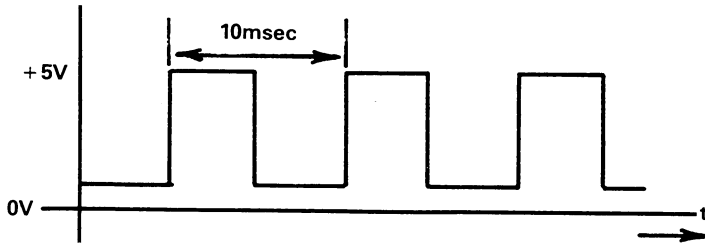

Figure 2-3. Square Wave Output Waveform

NOTE

In this example the Model 230 does not change range. If the Model 230 is programmed to change from one range into another (e.g. 10V to 1V), the output drops to zero for approximately 2msec between range changes.

Example 7 Using External Trigger (Input and Output)—The external trigger initiates the program mode (single, continuous or step) in the same manner as the START button. To output any programmed values the program mode must be selected, the OPERATE button enabled, and instrument must receive the external trigger input pulse.

The external trigger output is a pulse signifying the completion of a programmed dwell time. The pulse is present at the external trigger output in any of the three program modes. For the single or continuous program modes there is an output pulse at the end of every programmed dwell time. For the step program mode, there is an output pulse at the end of the programmed dwell time for the one memory location. To go on to the next step (memory location) and output another external trigger output pulse, another external trigger pulse is required.

Using the Model 619 in conjunction with the Model 230 can help illustrate this example. Like the Model 230, the Model 619 has external trigger input and output (electrometer complete and external trigger) lines. Connect the two instruments as shown in Figure 2-4. In this configuration and with the proper programming, the Model 230 will output the programmed voltage when the START button is pressed. At the end of the specified dwell time the Model 230 outputs the external trigger pulse. This pulse triggers the Model 619 to take a reading. When the Model 619 measurement cycle is completed it will output a trigger pulse (via the electrometer complete line) to the Model 230. The trigger pulse from the Model 619 to the Model 230 triggers the Model 230 to advance to the next memory location and output the next programmed voltage. The Model 230 must be in the step program mode for this example.

At this point the cycle repeats itself and keeps on repeating itself by advancing through the programmed memory locations of the Model 230. To stop the cycle, disconnect one of the trigger lines.

NOTE

The Model 619 can be set to the talk-only mode and connected to an IEEE compatible printer. The Model 619 measurement data would then be recorded by the printer automatically. This would free the operator from recording the data manually.

NOTE

Only the Model 619's that have the electrometer complete and external trigger connections can be used for this example.

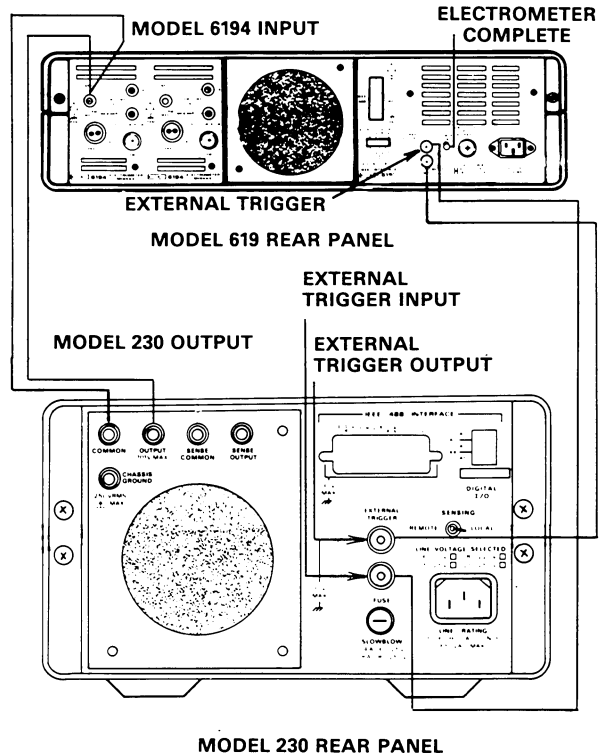

Figure 2-4. Using External Trigger

Example 8 - Using a Power Amplifier—The Model 230's maximum output power is $100\text{mA} \times 100\text{V} = 10\text{W}$. This power is sufficient for most applications of the Model 230. There are times however, when an increase in output power is required. In these applications the Model 230 can be used in conjunction with a power amplifier to increase the output power. The maximum output the Model 230 along with a power amplifier is 100W . Refer to Figure 2-5.

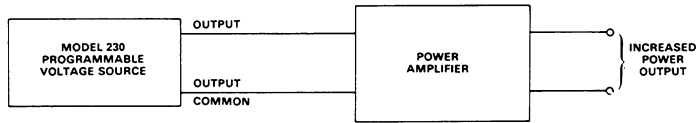

Figure 2-5. Using the Model 230 with a Power Amplifier

2.5 APPLICATIONS

2.5.1 Calibration

The Model 230's high accuracy allows it to be used as a voltage calibration source. The required voltage levels and current compliance can be stored into the appropriate memory locations. The three different program modes allow the operator to run through the programmed values either manually (step), or automatically (single or continuous). In the single or continuous program mode different dwell times can be programmed. This allows the operator to tailor the dwell time to his needs. The step program may be the best way to run through the calibration steps. In this mode the operator can manually step through the memory locations and therefore, output the voltage when it is required by the calibration procedure.

2.5.2 Active Loads

The Model 230 can be used as an active load as shown in Figure 2-6. In this application, the configuration is such that current flows into the Model 230. The Model 230 can operate as an active load but must remain within the operating limits specified in Figure 2-7.

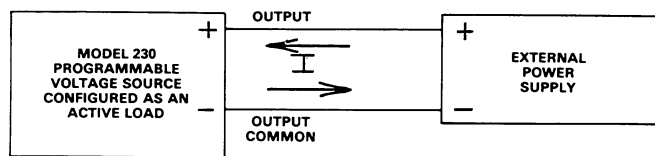

Figure 2-6. Model 230 Configured as an Active Load

2.5.3 Measure Dielectric Absorption

Dielectric absorption is an inherent characteristic of capacitors. This phenomenon is one where the capacitor recovers charge (hence voltage) after it has been discharged. The charge retention is a function of the type of dielectric material (e.g. Polystyrene, Tantalum, Mica, Ceramic, etc.) used in the capacitor. The circuit used is shown in Figure

2-9. The capacitor C_x is initially charged for a period of time, usually one to two minutes. Next, the voltage source E_1 is removed via S1 and the capacitor C_x is discharged via S2 through R_2 . The capacitor is allowed to set for a few minutes after S2 is opened and then the voltage is measured with the electrometer such as the Keithley Model 614 or Model 619. The electrometer, with its high input resistance is used because it draws virtually no charge from the capacitor during the measurement. The residual voltage E_2 on C_x is a measure of the dielectric absorption of the capacitor. Several consistent charge/discharge cycles are required for good relative measurements.

CAUTION

When the Model 230 is connected so as to consume power (that is, power is delivered to the Model 230 by an external power supply) care should be taken to limit the power delivered to the Model 230. Exceeding the limits specified in Figure 2-7 will result in damage to the instrument.

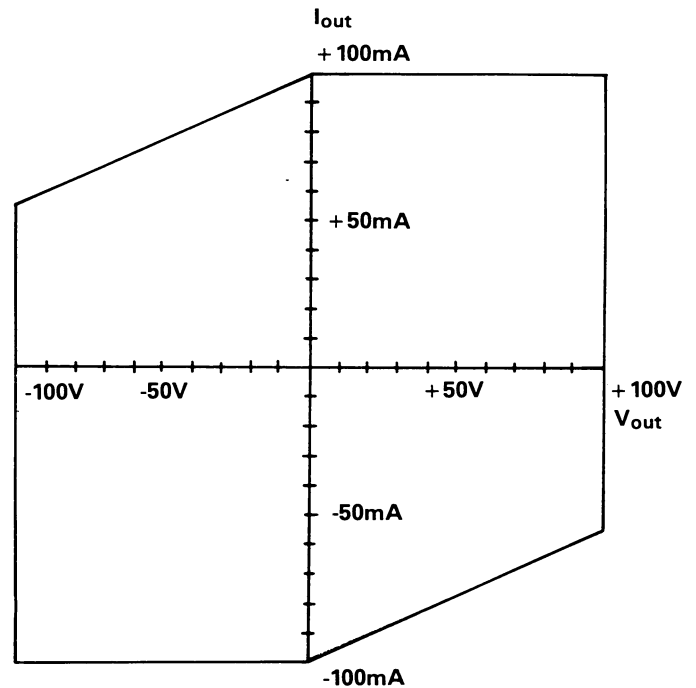

Figure 2-7. Model 230 Recommended Operating Limits

2.5.4 Insulation Resistance

The Model 230 can be used in conjunction with the Model 614 electrometer to measure high resistances such as insulation resistance and printed circuit board resistance. The constant voltage technique is an efficient method to measure high resistance. The Model 230 and the Model 614 are ideally suited for this application. Refer to the test circuit shown in Figure 2-8. The constant voltage is applied by the Model 230 and the Model 614 is used as an ammeter to directly measure the leakage current through the unknown

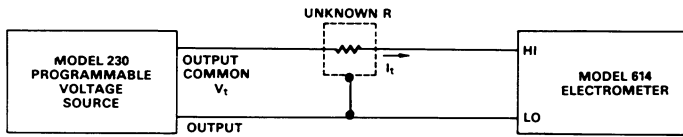

Figure 2-8. Measuring High Resistance

resistance. By knowing the value of the constant voltage and the value of the leakage current through the unknown resistance the resistance can be calculated from:

$$R = \frac{V_t}{I_t} \text{ where } V_t = \text{applied voltage}$$

$I_t = \text{measured current}$

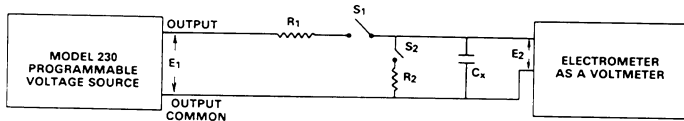

Figure 2-9. Measuring Dielectric Absorption

for example: $V_t = 100V$
 $I_t = 1pA$

$$R = \frac{100V}{1pA} = 10^{14}\Omega$$

SECTION 3 PERFORMANCE VERIFICATION

3.1 INTRODUCTION

Performance verification may be done upon receipt of the instrument to ensure that no damage or misadjustment has occurred during transit. Verification may also be performed whenever there is question of the instrument's accuracy and following calibration if desired.

NOTE

For instruments that are still under warranty (less than 12 months since date of shipment), whose performance falls outside specifications at any point, contact your Keithley representative or the factory immediately.

3.2 ENVIRONMENTAL CONDITIONS

Measurements should be made at 18-28°C and at less than 70% relative humidity unless otherwise noted.

3.3 RECOMMENDED TEST EQUIPMENT

Table 3-1 lists all the test equipment required for verification. If alternate equipment is used, the alternate test equipment's specifications must be at least as good as the equipment specifications listed in Table 3-1.

Table 3-1. Recommended Test Equipment

Item	Description	Specification	Mfr.	Model
A	DVM	.2V Range $\pm .005\%$ 2V Range $\pm .005\%$ 20V Range $\pm .005\%$ 200V Range $\pm .007\%$	Keithley	192

3.4 WARM-UP

The Model 230 must be turned on and allowed at least one hour for warm-up. If the instrument has been subjected to extremes of temperature, allow sufficient time for internal temperatures to reach normal operating conditions specified in paragraph 3.2. Typically it takes one hour to stabilize a unit that is 10°C (18°F) out of the specified temperature range.

3.5 PERFORMANCE VERIFICATION

WARNING

This procedure requires the use of high voltage and is intended for use by qualified test personnel only. Take care to prevent contact with live circuits which could cause electrical shock resulting in injury or death.

3.5.1 DC Voltage Accuracy Check

1. Set up the test configuration shown in Figure 3-1.
2. Select the DCV function and the 0.2V range on the Model 192.
3. Zero the Model 192 by:
 - A. Short the two test leads of the Model 192 together.
 - B. Press the ZERO button on the Model 192.
4. Program the Model 230 to output (operate LED on) +00.00-3V.
5. Verify the reading on the Model 192 to be less than $\pm 300\mu V$.
6. Program the Model 230 to output (operate LED on) +190.00-3V.
7. Verify the reading on the Model 192 to be between .190451 and 189549.
8. Program the Model 230 to output (operate LED on) +.0000+0V.
9. Select the 2V range on the Model 192. Also, press the ZERO button on the Model 192 to take it out of the zero mode.
10. Verify the reading on the Model 192 to be less than $\pm 1mV$.
11. Program the Model 230 to output (operate LED on) +1.9000+0V.
12. Verify the reading on the Model 192 to be between 1.90210 and 1.89790.
13. Program the Model 230 to output (operate LED on) +0.000+0V.
14. Verify the reading on the Model 192 to be less than $\pm 10mV$.
15. Select the 20V range on the Model 192.
16. Program the Model 230 to output (operate LED on) +19.000+0V.
17. Verify the reading on the Model 192 to be between 19.0210 and 18.9790.
18. Program the Model 230 to output (operate LED on) +00.00+0 and select the 2V range on the Model 192.
19. Verify the reading on the Model 192 to be less than $\pm 50mV$.
20. Select the 200V range on the Model 192.
21. Program the Model 230 to output (operate LED on) +100.00+0V.

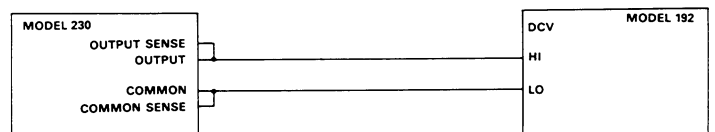

Figure 3-1. Model 230 Performance Verification

WARNING

This step requires the use of high voltage. Take care to prevent contact with live circuits which could cause electrical shock resulting in injury or death.

22. Verify the reading on the Model 192 to be between 100.107 and 99.893.

23. Program the Model 230 to the standby mode (operate LED off).
24. Repeat steps 2 through 23 with the Model 230 using negative source voltage.

This completes the performance verification for the Model 230. If the Model 230 is out of specification at any point in the preceding procedure refer to Section 5 Maintenance (Calibration) unless the Model 230 is under warranty.

SECTION 4 THEORY OF OPERATION

4.1 INTRODUCTION

This section contains circuit descriptions for the Model 230 Programmable Voltage Source. The information is arranged to provide a circuit description of individual functional circuit blocks. To facilitate understanding, the descriptions are keyed to accompany simplified block diagrams and schematics. Detailed schematics of the Model 230 are located in Section 6.

4.2 BLOCK DIAGRAMS

The circuitry of the Model 230 is represented by the two simplified block diagrams in Figure 4-1 and 4-2. Figure 4-1 shows a simplified block diagram of the Model 230's analog circuitry (power supply, range circuitry, amplifiers, etc.). Figure 4-2 shows a simplified block diagram of the Model 230's digital circuitry (microprocessor, RAM, ROM, VIA, etc.).

4.3 POWER SUPPLY

To facilitate understanding of the following discussion refer to schematic diagram 220-106 (sheet 2 of 2). The power supply is a conventional AC to DC power converter. Transformer T101 has three separate secondaries that are fed into three separate bridge rectifiers CR101, CR108 and the bridge configuration of CR102 through CR105. The output of CR101 is fed into regulator VR101 and is filtered by C107 and C103 producing the +5V digital supply. The output of CR108 is fed into VR102 and VR103 and is filtered by C119 through C122 to produce the positive and negative 15V supplies. The output of CR102 through CR105 is filtered by C117 and C118 to produce the positive and negative 125V supplies. R118 and R119 are bleeder resistors to prevent charge retention after AC power is removed. The parallel combination of C106 and R103 commit digital common to chassis and power line ground.

A tap off the primary of transformer T101 supplies the nominal 115VAC to the fan through connector P/J1005.

4.4 ANALOG BOARD

To facilitate understanding of the following discussion refer to schematic diagram 230-126 (sheets 1 and 2).

The heart of the analog board is the high voltage electrometer op amp which is centered on U315. U315 is bootstrapped up to the levels supplying Q314 and Q315 by Q312-Q315 and Q309-Q314 and their associated circuitry. Q308, R321, R330, R338, C315, C316 and C320 establish frequency stability for U315. R333, R336 and R337 serve as

an input voltage offset adjustment for U315. CR304 and CR307 provide input protection for U315.

The output stage drives analog common through a remote/local sensing scheme. Protection against an open sense line is provided by shunt circuitry C317, CR305, CR305 and CR308 through CR310.

To reduce errors the sense current must be minimized. A large portion of this error current is the differential base drive to Q314 and Q315. This current is sensed by the differential amplifier consisting of U316, R366 and R368 through R372. A voltage is developed by this circuitry across R373 which cancels the base drive differential to Q314/Q315.

A constant current source can be derived by a series voltage source and resistance from the output (analog common) to the amplifier input. A second fixed resistance, R357, to output common transforms the current source to a voltage source. The ratio of this resistance to the series feedback resistance sets the gain for the programmable voltage source to voltage output at a selectable level. Output common also has a remote sense capability which is shunted by a protection circuit CR311, CR313-CR315 and C324.

The resistance part of this series network is performed by range resistors R346, R351, R356 and R340 along with associated calibration potentiometers and resistances. JFET switches (Q301-Q307) are used to select which resistor is being used. Several of these JFET switches are organized in pairs which are used to provide voltage sensing at the resistor to compensate for the voltage drop in the current carrying JFET. U309 serves as a sense amplifier. R339 prevents a loss of sense input to U309 during FET switching. R340, R334 and R344 provide a calibrated divide by 10 network permitting the use of R356 on the lower two voltage ranges.

Drive for the JFET switches is obtained from section A of U310 and U313. U313 is a voltage comparator with open collector outputs. Combined with resistor pull-up network R332, this circuitry provides the voltage drive for the switching JFETs. R318 and R319 provide the voltage reference for these comparators.

The voltage source part of this series network centers around U305, a 12 bit digital to analog converter (DAC). Associated circuitry R301-R302, R309-R311 and R313-R315 is used to adjust offset and positive gain. Gain is set on the 10V range which is why R351 has no adjustment. C301 and C306 are for noise immunity and output response speed. C303 and C304 filter the power supply to U305. Following

this circuitry is a network providing a +/- operator to the output of U305. U306 provides the active portion while switches on U307 along with R316, R320, R322 and R324 provide a selectable gain of +1 or -1. R318 provides a gain adjust (-10V) for this operator. The output is fed to sense amplifier U309. R321 is an offset voltage adjustment for U312 and U315.

Serial to parallel shift/store registers U301, U302 and U303 provide digital control from the serial data link. Data is inputted via the clock and latch lines. Latch selects the data in mode as either recirculated data out (latch=logic 0) or the overcompliance (I-limit) information (latch=logic 1). This selection is performed by U304A and B, U311B and C and U308A.

The outputs of registers U301, U302 and U303 are "tri-state" under the control of the "ENB" (enable) signal to these devices. While in the "tri-state" condition, the outputs are held in a safe controlled condition by resistor networks R303 to R305. Gates U308C and D form a flip-flop for controlling the tri-state mode of U301, U302 and U303. This circuitry along with R306, R307, CR301, C302 etc., prevents erroneous current source outputs both on acquisition and loss of AC line power.

The remaining portion of the analog circuitry produces the selectable compliance current limit. The programmed limit is decoded by U301B which in turn drives relays K301 and K302 via U314. In order to detect I-limit condition the output voltage of U315 is also applied to a "window comparator" consisting of U312A and B. The comparator limits are set by resistor divider network R326 through R328. U313A and B's open collector output are "wire ORed" through pull up resistor R331. Whenever the voltage exceeds the comparator limits a "logic 1" signal is developed through current limiting resistor R325 to the output of inverter U311D.

The +5V required by the digital circuitry on the analog board is supplied by VR301. This voltage is also supplied to the digital board for use by the optically isolated portion of the circuitry.

K303 requires 24VDC which is supplied by CR303 and C313.

4.5 DIGITAL BOARD (Microcomputer)

To facilitate understanding of the following discussion refer to schematic diagram 220-106 (sheet 1 of 2). For an overall block diagram of the digital circuitry refer to Figure 4-2.

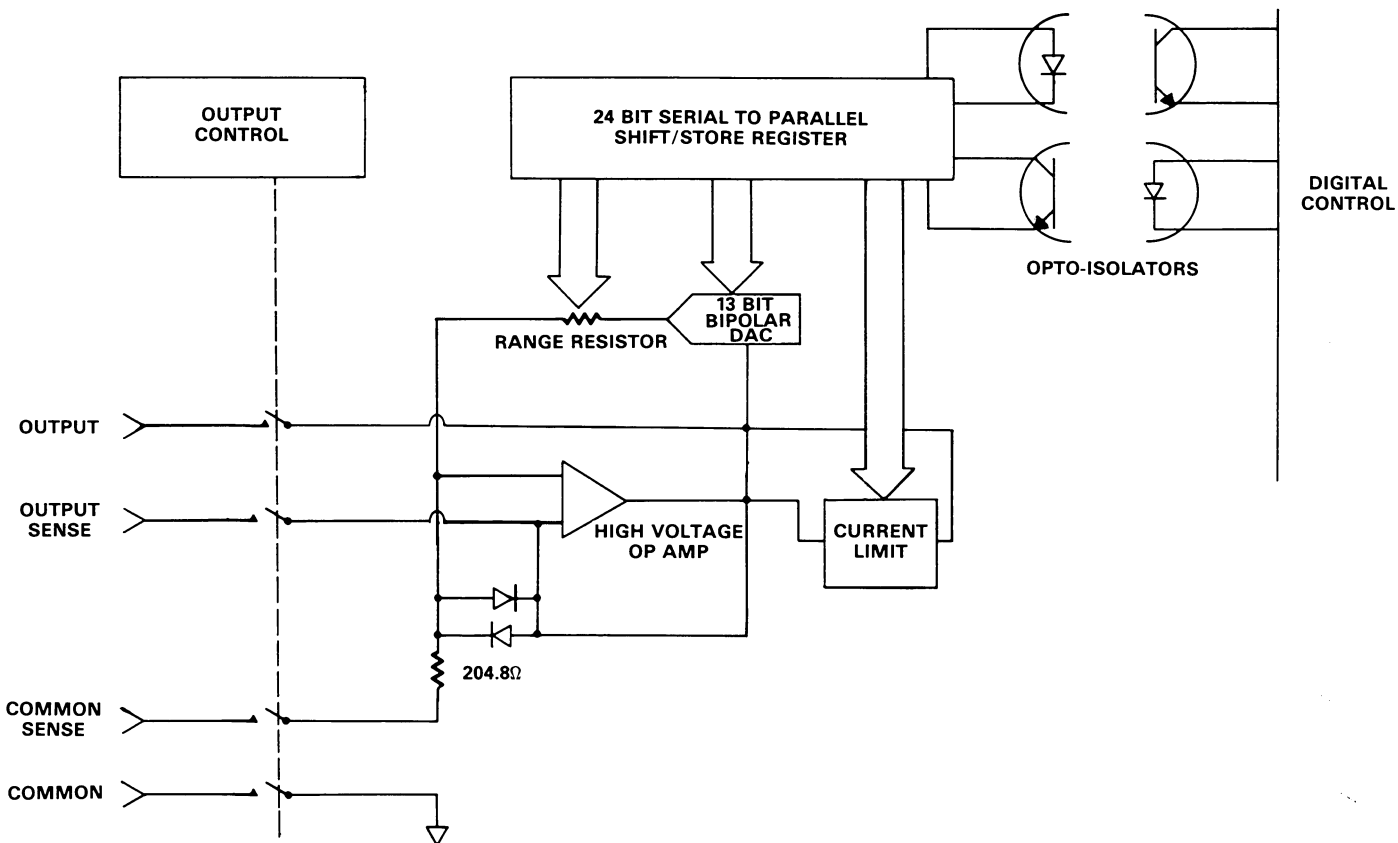

Figure 4-1. Analog Circuitry Block Diagram

The microcomputer and its associated logic circuitry, controls front panel functions (source, dwell time, program control etc.), operation of the front panel display and data through the IEEE-488 interface circuitry.

The microcomputer includes a 6808 microprocessing unit U115; a 6522 versatile interface adapter U114; two 2732 ROMs U109 and U111; four 2114 RAMs U101, U103, U105 and U107; an address decoder U110; a data bus driver U116 and the necessary reset logic. The memory utilized in this system is shown in the memory map (Figure 4-3). Using address lines A13, A14 and A15; U110 sections the 64k of memory space into 8k and 4k segments. The total memory used is a small portion of the entire addressing capabilities of the 6808 microprocessor U115. Memory locations for the 64k addresses are assigned the values 0000_{16} through $FFFF_{16}$.

Interfacing of the microprocessor with the RAMs, ROMs, Front Panel, VIA or the IEEE-488 interface is controlled by the address decoder, U110.

Partial address decoding is used in this system. The function selected is determined by the state of the address lines A13, A14 and A15. These address lines determine which output is selected at the decoder U110 in accordance with the memory map. Only one of the devices (RAM, ROM, VIA, etc.) will have access to the data bus at any time. The address decoder selects one of the devices only after a Valid Memory Address VMA has been asserted at the decoders input EN (pin 6). The VMA signal is generated by the 6808 microprocessor.

Timing for the computing sequence is provided by the 4MHz crystal Y101. The 6808 microprocessor divides this signal by four to produce a 1MHz signal at the $\Phi 2$ output (pin 37).

U102, U104, U106C, U108C and their associated circuitry, forms a reset network (watchdog) which resets the microprocessor, VIA and the IEEE-488 interface. The circuit actuates in the event the front panel display is not updated after a specific period of time has elapsed due to a lost program or power line transient.

The digital circuitry is optically isolated from the analog circuitry by AT101 through AT104, U113A, B, U117 and their associated circuitry. The output signals consist of latch, clock and data out. These signal lines permit serial communication to the analog circuitry. The data in signal line is received from the analog circuitry and is either the recirculated data or the overcompliance (I-limit) data depending on the state of the latch line. When the latch line is a logic 1, the data in line will represent the compliance state (logic 1 implies an overcompliance or I-limit). When the latch line is a logic 0, the data in line will be the recirculated data sent out to the analog side as data out. This data is inverted on the digital side of the isolation.

The remaining circuitry on the digital board consists of external trigger inputs and outputs. C123, CR112, CR111, R121 and R128 comprise an input protection network for triggering input to PB6 of the VIA (U114). U113D, CR109, CR110, R127 and R122 buffer a triggered output originated on PB3 of the VIA (U114).

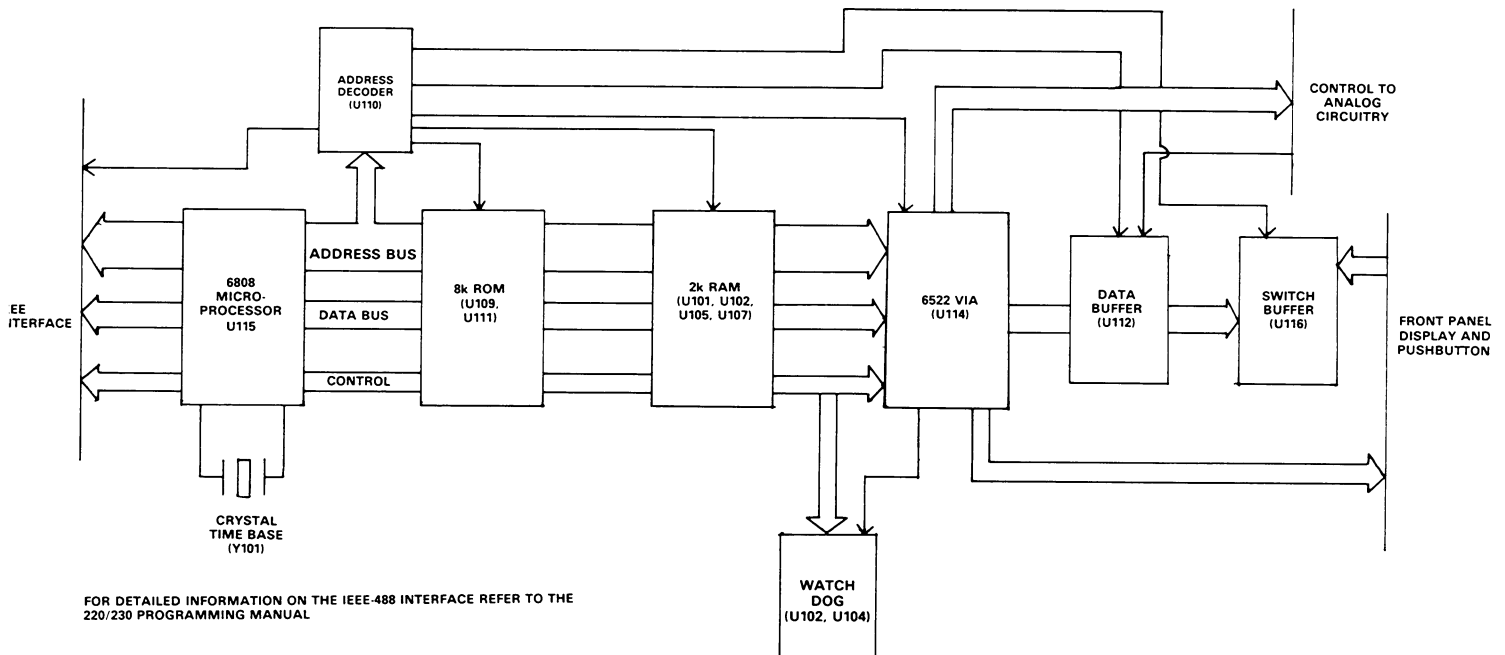

Figure 4-2. Digital Circuitry Block Diagram

4.6 DISPLAY CIRCUIT

The display information is outputted on PA0 through PA7 on the VIA (I/O) bus. The information is updated at a 1kHz rate which means, each digit is on for 1msec. Each update begins by presenting new segment information on the VIA (I/O) bus (PA0-PA7) and outputting a clock pulse on CA2. The clock pulse inputs to U203 and shifts a digit enable bit to the next digit to be enabled. Every eight times the display is updated, a digit enable bit is generated at PB5 and goes to the enable data input of the shift register.

The first four digit drivers drive the rows of the switch matrix. The switches are arranged in a four by six matrix. The segment drivers are Q201 through Q208. In addition to driving the various segments, they also activate the appropriate LEDs.

MEMORY ADDRESS (HEX)	I/O FUNCTION
0000	RANDOM ACCESS MEMORY U101 AND U105
1FFF 2000	
3FFF 4000	RANDOM ACCESS MEMORY U103 AND U107
4FFF 5000	
5FFF 6000	DATA BUFFER U112
7FFF 8000	VERSATILE INTERFACE ADAPTER U114
	SWITCH BUFFER (FROM FRONT PANEL) U116
	IEEE-488 INTERFACE
9FFF A000	READ-ONLY MEMORY U111
BFFF C000	READ-ONLY MEMORY U109
CFFF D000	
DFFF E000	NOT ACCESSABLE
EFFF F000	NOT ACCESSABLE
FFFF	VECTOR JAM TO D000 THROUGH DFFF FOR U109

Figure 4-3. Memory Map

SECTION 5 MAINTENANCE

5.1 INTRODUCTION

This section contains information necessary to maintain the Model 230 Programmable Voltage Source. Calibration adjustment, troubleshooting, fuse replacement, line voltage selection, fan filter cleaning and all information pertinent to maintenance is provided.

5.2 CALIBRATION

Calibration should be performed yearly (every 12 months) or whenever performance verification (see Section 3) indicates that the Model 230 is out of specification. If any step in the calibration procedure cannot be performed properly, refer to paragraph 5.4 for troubleshooting information or contact your Keithley representative or the factory.

WARNING

All service information is intended for qualified electronic maintenance personnel only.

5.2.1 Recommended Test Equipment

Recommended test equipment for calibration is listed in Table 5-1. Alternate test equipment may be used. However, the accuracy of the alternate test equipment must at least be equal to the specifications in Table 5-1.

5.2.2 Environmental Conditions

Calibration should be performed under laboratory conditions having an ambient temperature of $23^{\circ}\text{C} \pm 1^{\circ}\text{C}$ and a relative humidity of less than 70%.

5.2.3 Warm-Up

The Model 230 must be turned on and allowed one hour for warm-up. If the instrument has been subjected to extremes of temperature, allow sufficient time for internal temperatures to reach normal operating conditions. Typically, it takes one hour to stabilize a unit that is 10°C (18°F) out of the specified temperature range.

5.2.4 Calibration Adjustments

Use the following procedure and make the adjustments indicated to calibrate the Model 230. To locate adjustment

points, remove the top cover and refer to the analog board shield. Minimize the time the top cover is removed. If any step in the calibration procedure cannot be completed refer to paragraph 5.8 (Troubleshooting).

WARNING

To prevent a shock hazard, turn the instrument off, remove the line cord and all test leads from the instrument before removing the top cover.

WARNING

This procedure requires the use of high voltage. Take care to prevent contact with live circuits that could cause electrical shock resulting in injury or death. Use an insulated tool when making adjustments.

NOTE

Calibrate the Model 230 using local sensing.

1. Set up the test circuit shown in Figure 5-1.
2. Select the 2VDC range on the Model 192.
3. Program the Model 230 to output $+ .0000 + 0$ volts, with a current compliance of 20mA.
4. Record the reading on the Model 192 to within $\pm 100\mu\text{V}$.
5. Program the Model 230 to output $-0.0000 + 0$ volts with a current compliance of 20mA.
6. Record the reading on the Model 192 to within $\pm 100\mu\text{V}$.
7. Calculate the average of the two recorded readings by adding them together and dividing the sum by two.
8. Adjust R301 (+ to—Zero Span) for the calculated value to within $\pm 100\mu\text{V}$.
9. Adjust R321 (Span Zero) to null the reading obtained in step 8 to within $\pm 100\mu\text{V}$.
10. Set up the test circuit as shown in Figure 5-2.
11. Program the Model 230 to output $+ 00.00-3$ volts.
12. Adjust R333 (Range Zero) for a reading on the Model 192 of $.00000 \pm 10\mu\text{V}$.
13. Select the 20VDC range on the Model 192.
14. Program the Model 230 to output $+ 19.000 + 0$ volts.
15. Adjust R302 (10V Span) for a reading on the Model 192 of $19.0000 \pm 1\text{mV}$.
16. Program the Model 230 to output $-19.000 + 0$ volts.
17. Adjust R320 (-10V Span) for a reading on the Model 192 of $-19.0000 \pm 1\text{mV}$.

Table 5-1. Recommended Test Equipment

Item	Description	Specification	Mfr.	Model
A	DVM	2VDC Range $\pm 0.005\%$ 20VDC Range $\pm 0.005\%$ 200VDC Range $\pm 0.007\%$	Keithley	192

18. Select the 200VDC range on the Model 192.
19. Program the Model 230 to output +100.00 +0 volts.

WARNING

This step requires the use of high voltage. Take care to prevent contact with live circuits which could cause electrical shock resulting in injury or death.

20. Adjust R342 (100V Span) for a reading on the Model 192 of 100.000 ±5mV.
21. Program the Model 230 to the standby mode.
22. Select the 2VDC range on the Model 192.
23. Program the Model 230 to output +1.9000 +0 volts.
24. Adjust R343 (1V Span) for a reading on the Model 192 of 1.90000 ±100µV.
25. Program the Model 230 to the standby mode.
26. Select the .2VDC range on the Model 192. Short the two input leads together and press the ZERO button on the Model 192.
27. Reconnect the input leads to the Model 230's output and output common.
28. Program the Model 230 to output +190.00-3 volts.
29. Adjust R344 (100mV Span) for a reading on the Model 192 of .190000 ±10µV.
30. Program the Model 230 to the standby mode.

This completes the calibration of the Model 230. To verify correct calibration of the Model 230 refer to Section 3.

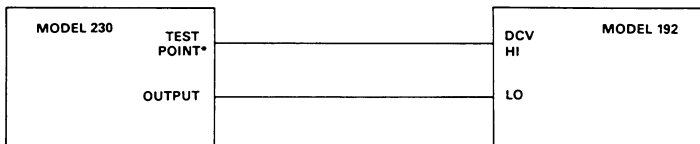

*THE TEST POINT IS LOCATED ON THE ANALOG BOARD

Figure 5-1. Zero Span

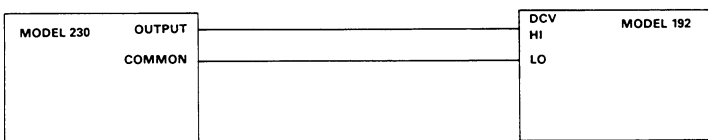

Figure 5-2. 100mV to 100V Calibration

5.3 FUSE REPLACEMENT

If power fails, first verify that the fuse (F101) is not defective before disassembling the Model 230. If the line voltage setting is changed (S102) the fuse must be replaced according to Table 5-2 and 5-3. The fuse is accessible from the rear panel. To replace the fuse proceed as follows:

1. Turn power off and disconnect the line cord.

WARNING

To prevent a shock hazard, always turn the

instrument off and disconnect the line cord before replacing the line fuse.

2. The fuse carrier is spring loaded. Using a slotted screwdriver, push the fuse carrier in and rotate ¼ turn counterclockwise. The carrier and fuse will eject from the holder.
3. Remove the fuse from the carrier and replace per Table 5-2 and 5-3.

CAUTION

Do not install a fuse with a higher rating than specified in Tables 5-2 and 5-3. Instrument damage may result.

4. To install the properly rated fuse and carrier into the holder, reverse the procedure in step 2.

Table 5-2. Fuse Replacement, 3AG Size

Line Voltage	Fuse F101	Keithley Part No.
90V-110V*	3/4A, 250V, 3AG, SLO BLO	FU-19
105V-125V	3/4A, 250V, 3AG, SLO BLO	FU-19
180V-220V*	3/8A, 250V, 3AG, SLO BLO	FU-18
210V-250V	3/8A, 250V, 3AG, SLO BLO	FU-18

*Requires special factory installed transformer TR-187.

Table 5-3. Fuse Replacement 5mm Size

Line Voltage	Fuse F101	Keithley Part No.
90V-110V*	0.8A, 250V, SLO BLO	FU-52
105V-125V	0.8A, 250V, SLO BLO	FU-52
180V-220V*	0.4A, 250V, SLO BLO	FU-53
210V-250V	0.4A, 250V, SLO BLO	FU-53

*Requires special factory installed transformer TR-187.

5.4 LINE VOLTAGE SELECTION

Set up the Model 230 to operate on the available AC line voltage as follows:

WARNING

To prevent a shock hazard, turn the instrument off and disconnect the line cord. Also, remove all test leads from the instrument before removing the top cover.

1. Remove the top cover (see paragraph 5.5 step 1).
2. Refer to Table 5-4 and set switch S102 (located underneath the IEEE-488 interface board and near transformer T101).
3. Install proper fuse per paragraph 5.3.

NOTE

The line voltage setting of the instrument is marked on the rear panel. The following pro-

cedure can be used either to confirm the factory setting, or to set up the instrument for operating on another voltage range. If the line voltage range is changed, the box next to the selected line voltage should be appropriately marked as an external reminder of the setting. Use a water soluble marking pen.

Table 5-4. Line Voltage Selection

Line Voltage	Line Frequency	Switch S102
90V-110V*	50Hz-60Hz	115V
105V-125V	50Hz-60Hz	115V
195V-235V*	50Hz-60Hz	230V
210V-250V	50Hz-60Hz	230V

*Requires special factory installed transformer TR-187.

5.5 DISASSEMBLY

If it is necessary to remove or replace a component, use the following procedure to aid in disassembly of the Model 230.

1. Remove the top cover as follows:

WARNING

Turn the instrument off, remove all test leads from the instrument and disconnect the power cord before removing the top cover.

- a. Remove the two retaining screws located at the rear of the instrument.
 - b. Grasping the top cover at the rear, carefully lift it off the instrument.
 - c. When installing the top cover, make sure that the three tabs located at the front of the cover engage in the front panel assembly.
2. Remove the IEEE-488 interface board.
 - a. Unplug ribbon cable (J/P1004) at the mother board.
 - b. Remove the phillips head screw located near J1004 on the interface board.
 - c. Remove the two retaining bolts that secure the interface board and IEEE-488 connector to the rear panel.
 - d. Lift the interface board out of the mainframe.
 3. Remove the analog board shield.
 - a. Remove the four slot head screws that secure the shield to the analog board.
 - b. Lift the shield and the four slot head screws away from the analog board.
 4. Unplug the ribbon cable (J/P1003) from the analog board.
 5. Unplug the output molex connector (J/P1009).
 6. Lift the analog board out of the mainframe.
 7. Remove the mother board from the case.
 - a. Remove the four plastic standoffs.
 - b. Remove the two phillips head screws that secure the case to the rear panel.
 - c. Unplug the display ribbon cable (J/P1002) from the mother board.

- d. Grasp the mother board and rear panel simultaneously. Lift the mother board and rear panel up toward the rear of the instrument. Then lift the mother board and rear panel out of the case.
8. Remove the display board.
 - a. Remove the two phillips head screws that secure the display board to the front panel.
 - b. Remove the front panel buttons.
 - c. Lift the display board out of the case.
 9. For reassembly, perform steps 1-8 in reverse order.

NOTE

When installing J/P1004, J/P1003 and J/P1002, be sure to align pin one of the connector to pin one of the cable.

5.6 FAN FILTER MAINTENANCE

The internal temperature generated by the Model 230 necessitates the forced air cooling provided by the fan. The fan has an air filter which keeps the Model 230 relatively free of dust and dirt. Dust and dirt collect on the filter and impede the air flow through the instrument. Lack of air flow will cause overheating. Therefore, the filter must be clean in order for the Model 230 to achieve optimum performance.

To clean the filter:

1. Remove the filter from the fan.
2. Use compressed air to remove the dust and dirt from the filter. If the filter is excessively dirty, wash the filter in mild soap and water and blow dry it with compressed air.
3. Reinstall the filter.

5.7 SPECIAL HANDLING OF STATIC SENSITIVE DEVICES

MOS devices are designed to function at high impedance levels. Normal static charge can destroy these devices. Table 5-5 lists all the static sensitive devices of the Model 230. Steps 1 through 7 provide instruction on how to avoid damaging these devices.

Table 5-5. Model 230 Static Sensitive Devices

Reference Designation	Keithley Part No.
U101, U103, U105, U107	LSI-15
U102	IC-197
U109	230-800-B6
U111	230-801-B6
U112, U301, U302, U303, U401	IC-251
U114	LSI-28
U115	LSI-27
U116	IC-250
U304	IC-138
U305	IC-323
U308	IC-102
U310	IC-312
U402	IC-130
U404	LSI-49

1. Devices should be handled and transported in protective containers, antistatic tubes or conductive foam.
2. Use a properly grounded work bench and a grounding wrist strap.
3. Handle device by the body only.
4. PC boards must be grounded to bench while inserting devices.
5. Use antistatic solder suckers.
6. Use grounded tip soldering irons.
7. After devices are soldered or inserted into sockets they are protected and normal handling can resume.

5.8 TROUBLESHOOTING

The troubleshooting information in this section is intended for use by qualified personnel who have basic understanding of the analog and digital circuitry used in a precision test instrument. Instructions have been written to assist in isolating the defective circuit. Isolating the defective component has been left up to the troubleshooter. Refer to Table 5-6 for power supply checks. Refer to Table 5-7 for Analog board checks. Refer to Table 5-8 for digital circuitry checks. Refer to Table 5-9 for display board checks. Refer to Table 5-10 for IEEE-488 interface board checks.

NOTE

For instruments that are still under warranty (less than 12 months since date of shipment), whose performance falls outside specification at any point, contact your Keithley representative or the factory before attempting troubleshooting or repair other than fuse replacement.

5.8.1 Digital Self Test

Upon power-up the Model 230 performs a digital self test of the RAM (2114's) chips and a cyclic redundancy check (CRC) of the ROM (2732's) chips. If the self test or the CRC reveals a problem with any of the memory chips, the Model 230 will display an error message corresponding to the defective chip. For example; the digital self test reveals that RAM chip number four is defective. The Model 230 displays a flashing:

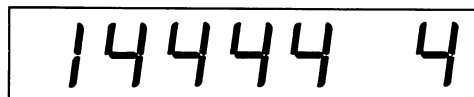

This informs the operator that RAM chip number four is defective. Refer to Figure 5-3 for chip number assignment.

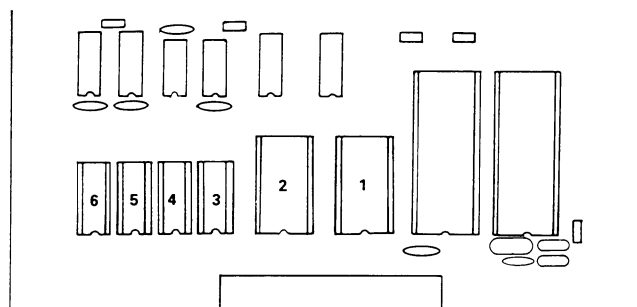

Figure 5-3. Memory Chip Number Assignment

5.9 CURRENT LIMIT MODIFICATION

In some applications it may be advantageous to modify the current limit value. For instance, the application may require greater than 2mA but less than 20mA current compliance or

Table 5-6. Power Supply Checks

Step	Item/Component	Required Condition	Remarks
		Unit turned on, properly rated F101 has continuity. Line selector switch S102 verified in correct position.	
1	Q315 Collector	+ 130VDC \pm 15%	+ 125 Volt Supply*
2	Q314 Collector	- 130VDC \pm 15%	- 125 Volt Supply*
3	VR301 Input	+ 15VDC \pm 15%	+ 15 Volt Supply**
4	U305 pin 14	- 15VDC \pm 15%	- 15 Volt Supply**
5	U305 pin 13	+ 5VDC \pm 5%	+ 5 Volt Digital Supply**

*Referenced to output common.

**Referenced to analog common.

***Referenced to digital common.

greater than 20mA but less than 100mA current compliance. For this reason the 20mA current can be modified for special user application. Resistors R353, R354, R359 and R360 are mounted in sockets to permit replacement in order to modify the current compliance. The replacement resistors for R353, R354, R359 and R356 should have specifications in accordance with Table 5-11. Table 5-12 provides approximate resistor values for various current limit values.

To calculate the appropriate resistor values use the following formulas. For $2\text{mA} > I_L < 100\text{mA}$

$$\text{For R353 and R359; } R_1 = \frac{0.65}{I_L} - 6.2$$

$$\text{For R354 and R360; } R_2 = [0.6 / (1\text{mA} + I_L \times 0.2)] - 28 - R_1$$

NOTE

The display will still require a 20mA input to select this current limit.

Table 5-7. Analog Board Checks

Step	Item/Component	Required Condition	Remarks
		Program the Model 230 to output 1V on the 1V range.	
1	U313 pin 1**	≈ +5V	FET Drive for 1V range
2	U313 pin 2**	≈ -15V	FET Drive for 100mV range, turned off.
3	U313 pin 13**	≈ -15V	FET Drive for 100V range, turned off.
4	U313 pin 14**	≈ -15V	FET Drive for 10V range, turned off.
5	U309 pin 2 and 3**	+5V (within 10mV of each other)	Input to sense amplifier.
6	U309 pin 6*	+5V	Output of sense amplifier.
7	U315 pin 6*	-1.9V	Output of the high voltage op amp.
8	U312 pins 1 and 2*	-15V	Window comparator circuit detecting an overcompliance condition.
		Program the Model 230 for 20mA compliance.	
9	U312 pins 1 and 2*	+5V	Window comparator circuit detecting compliance as normal.
10	U306 pin 6*	+5V	Active portion of the + / - operator in positive output (input to sense amplifier).
11	U307 pin 11*	0V	Selectable +1 and -1 gain switch for positive output.
12	U307 pin 3*	+5V	Selectable +1 and -1 gain switch for positive output.
13	U307 pin 14*	+5V	Selectable +1 and -1 gain switch for positive output.
		Program the Model 230 to output -1V on the 1V range.	
14	U306 pin 6*	-5V	Active portion of the + / - operator in negative output (input to sense amplifier).
15	U307 pin 11*	+5V	Selectable +1 and -1 gain switch for negative output.
16	U307 pin 3*	0V	Selectable +1 and -1 gain switch for negative output.
17	U307 pin 14*	0V	Selectable +1 and -1 gain switch for negative output.
18	U305 pins 16 and 24*	+6.3V	Voltage Reference of the 12 bit DAC.
		Program the Model 230 to output 0V.	
19	U305 pins 1 through 12*	+5V	Input data to the 12 bit DAC (U305).

Table 5-7. Analog Board Checks (Cont.)

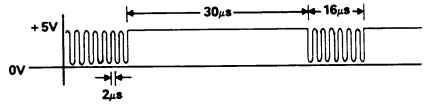
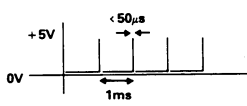
Step	Item/Component	Required Condition	Remarks
20	U301 pin 3* U302 pin 3* U303 pin 3* U304 pin 12*		Clock for U301, U302 and U303
21	U311 pin 9* U303 pin 1* U302 pin 1* U301 pin 1* U304 pin 2*		Latch line

*Reference to Analog Common (Guard)

**Reference to Output Common

Table 5-8. Digital Circuitry Checks



Step	Item/Component	Required Condition	Remarks
1	U115 pins 8 and 35 referenced to pins 3, 36 and 21 (digital common).	+5V ±5%	+5 Volt Digital Supply
2	U315 pin 37 (Φ2)	0V to 4V squarewave at 1MHz	1MHz Clock
3	U115 pin 40 (reset)	+5V ±5%	Reset Line
4	U114 pin 15	Negative going pulse (+5V to 0V) occurring every 8msec	Strobe for display board.
5	U114 pin 39	Negative going pulse (+5V to 0V) occurring every 1msec	Clock input for Display Board
6	U115 pin 4, U114 pin 21	1kHz clock	IRQ Line
7	U111, U110, U103, U105 U101 and U107	RAM and ROM (see paragraph 5.8.3 Digital Self Test)	Digital Self Test
8	U117 pin 6 (referenced to Analog Common)		Data Out Line (Analog Side) with the Model 230 programmed to 00.00.
9	U117 pin 4 (referenced to Analog Common)		Data in Line (Analog Side) with the Model 230 programmed to 00.00
10	U113 pin 3 (referenced to Digital Common)		Clock to Analog Side
11	U113 pin 6 (referenced to Digital Common)		Latch Enable

Table 5-9. Display Board Checks

Step	Item/Component	Required Condition	Remarks
1	Display	Turn on Power +1.8.8.8.8+1.8	All display segments and LED's will light for several seconds. If low, check per Table 5-6. Update Data Clock
2	U203 pins 2, 9 and 14	+5V ± 5%	
3	U203 pin 1		
4	U203 pin 8		

Table 5-10. IEEE-488 Interface Board Checks

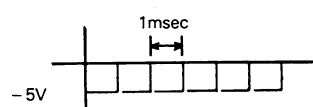
Step	Item/Component	Required Condition	Remarks
1	U404 pins 2 and 40 referenced to pin 20 (digital common)	+5V ± 10% referenced to Digital Common	+5V Digital Supply
2	S401 (A1-A5)	In the "1" position the switch is pulled up to +5V ± 10%	Primary Address
3	U404 pin 18 (ΦE)	1MHz square wave at 0V to +5V	Clock to U404
4	U404 pin 9	+5V signal being pulsed to 0V every 1msec	IRQ Line
5	U404 pin 19	+5V (logic "1") Cycle power and program the Model 230 into Remote (primary address 13)	RESET Line
6	U405 pins 19 and 2 (D1 and B1)	Logic "0" (3V typical)	Information across bus transceiver.
7	U405 pins 18 and 3 (D2 and B2)	Logic "1" (3.3V typical)	Information across bus transceiver.
8	U405 pins 17 and 4 (D3 and B3)	Logic "0" (≈ 0V) (.3V typical)	Information across bus transceiver.
9	U405 pins 16 and 5 (D4 and B4)	Logic "0" (0.3V typical)	Information across bus transceiver.
10	U405 pins 15 and 6 (D5 and B5)	Logic "1" (3.3V typical)	Information across bus transceiver.
11	U405 pins 14 and 7 (D6 and B6)	Logic "0" (0.3V typical)	Information across bus transceiver.
12	U405 pins 13 and 8 (D7 and B7)	Logic "1" (3.3V typical)	Information across bus transceiver.
13	U405 pins 12 and 9 (D8 and B8)	Logic "1" (3.3V typical)	Information across bus transceiver.

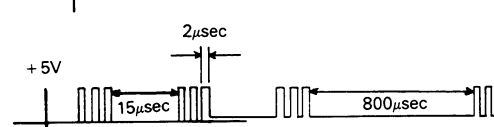
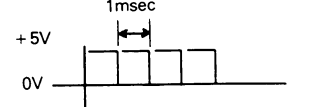
Table 5-11. Resistor Specifications

	Tolerance	Power
R353 R359	± 1%	1/8W
R354 R360	± 5%	1/4W

Table 5-12. Suggested Current Limit Modification

I _{Limit}	R353 R359	R354 R360
5mA	124Ω	148Ω
30mA	15Ω	42Ω
50mA	6.8Ω	20Ω

SECTION 6 REPLACEABLE PARTS

6.1 INTRODUCTION

This section contains replacement parts information, schematic diagrams, and component location drawings for the Model 230. An exploded view of the Model 230 is shown in Figure 6-1, while an illustration of the Fan Assembly is shown in Figure 6-2.

6.2 PARTS LIST

Parts are listed alphabetically in order of their circuit designations. Table 6-1 contains an index of the schematic diagrams and component location drawings included at the end of this section. Table 6-2 contains a parts list for the Model 230 motherboard. Table 6-3 contains a parts list for the display board. Table 6-4 contains a parts list for the analog board. Table 6-5 contains a parts list for the IEEE interface board.

6.3 ORDERING INFORMATION

To place an order, or to obtain information concerning replacement parts, contact your Keithley representative or the factory. See the inside front cover for addresses. When ordering include the following information:

1. Instrument Model Number
2. Instrument Serial Number
3. Part Description
4. Circuit Description (if applicable)
5. Keithley Part Number

If an additional instruction manual is required, order the manual package (Keithley Part Number 230-901-00). The manual package includes an instruction manual and all pertinent addenda.

6.4 FACTORY SERVICE

If the instrument is to be returned to the factory for service, complete the service form which follows this section and return it with the instrument.

6.5 SCHEMATIC DIAGRAMS AND COMPONENT LOCATION DRAWINGS

Schematic diagrams and component location drawings follow the replaceable parts list information in the order listed in Table 6-1.

Table 6-1. Index of Model 230 Schematics and Component Layouts

Figure	Title
6-3	Display Board, Component Location Drawing
6-4	Mother Board, Component Location Drawing
6-5	Analog Board, Component Location Drawing
6-6	IEEE Interface Board, Component Location Drawing
6-7	Display Board, Schematic Diagram
6-8	Digital Circuitry, Schematic Diagram
6-9	Analog Board, Schematic Diagram
6-10	IEEE Interface Board, Schematic Diagram

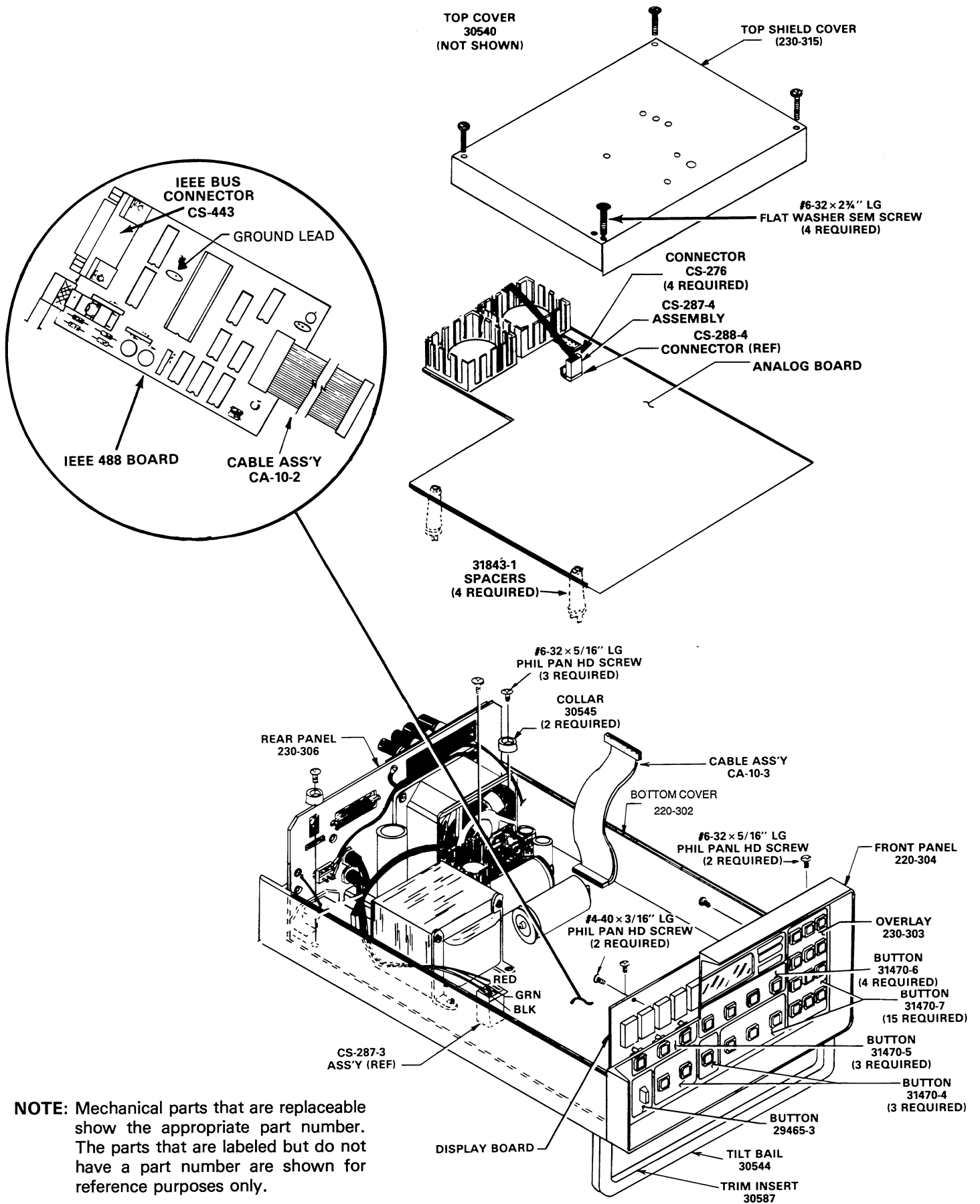

NOTE: Mechanical parts that are replaceable show the appropriate part number. The parts that are labeled but do not have a part number are shown for reference purposes only.

Figure 6-1. Model 230 Exploded View

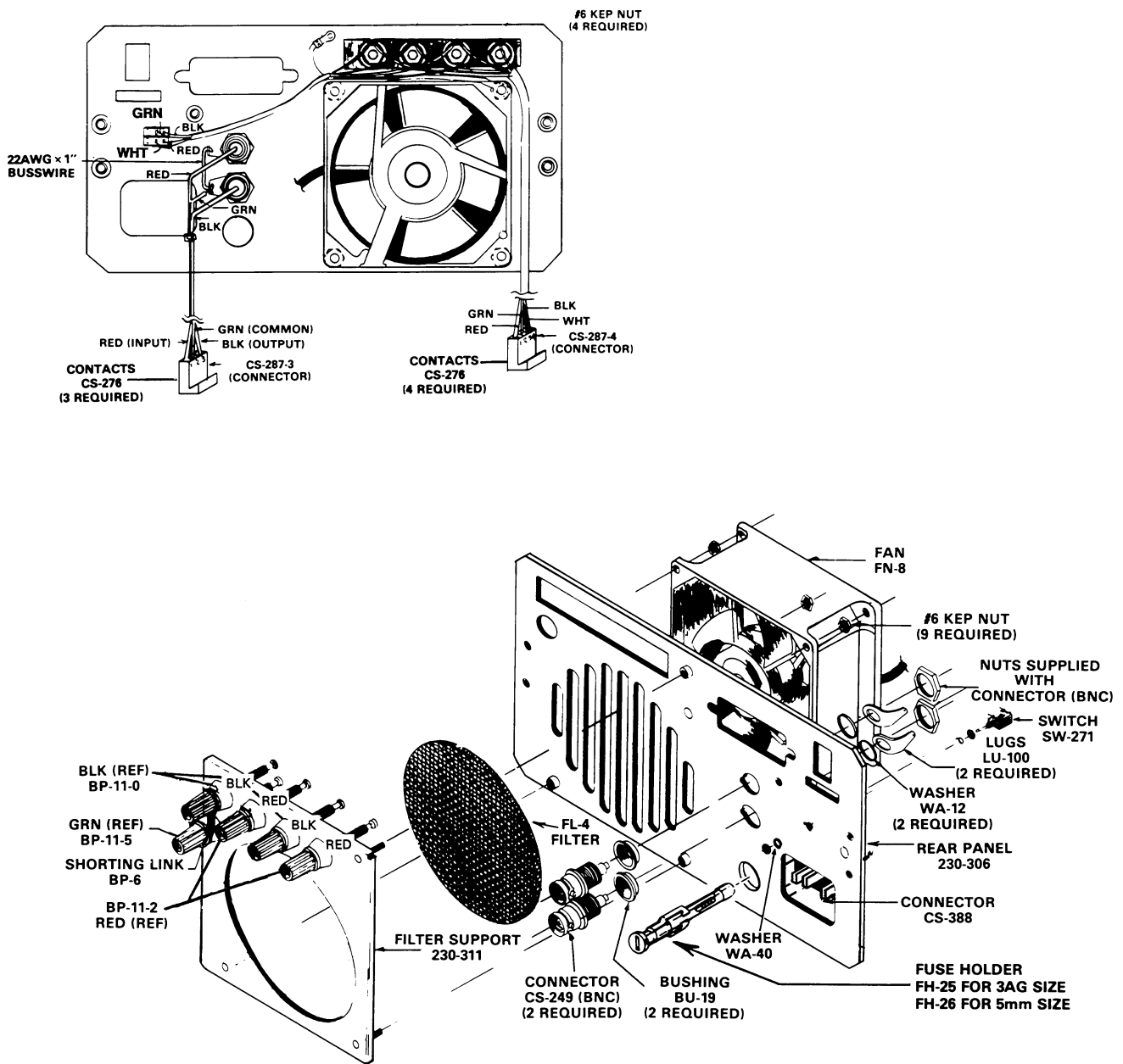

NOTE: Mechanical parts that are replaceable show the appropriate part number. The parts that are labeled but do not have a part number are shown for reference purposes only.

Figure 6-2 Model 230 Fan Assembly

Table 6-2. Mother Board D220-103, Parts List

Circuit Desig.	Description	Location		Keithley Part No.
		Sch.	Pcb.	
AT101	Optical Isolator, 6N137	G1	D4	IC-292
AT102	Optical Isolator, 6N137	G3	D4	IC-292
AT103	Optical Isolator, 6N137	G2	D5	IC-292
AT104	Optical Isolator, 6N137	G3	D5	IC-292
C101	.1 μ F, 16V, Ceramic Disc	E4	D2	C-238-.1
C102	.1 μ F, 16V, Ceramic Disc	G4	D2	C-238-.1
C103	10 μ F, 25V, Aluminum Electrolytic	D4	D2	C-314-10
C104	6800pF, 500V, Ceramic Disc	F5	D2	C-22-.0068
C105	.1 μ F, 16V, Ceramic Disc	E5	D2	C-238-.1
C106	.01 μ F, 500V, Ceramic Disc	B4	G3	C-22-.01
C107	10,000 μ F, 25V, Aluminum Electrolytic	C4	G3	C-342-10,000
C108	.1 μ F, 16V, Ceramic Disc	F2	D3	C-238-.1
C109	.1 μ F, 16V, Ceramic Disc	F1	D4	C-238-.1
C110	.1 μ F, 16V, Ceramic Disc	C1	C4	C-238-.1
C111	.1 μ F, 16V, Ceramic Disc	G3	E4	C-238-.1
C112	.1 μ F, 16V, Ceramic Disc	G2	E5	C-238-.1
C113	.1 μ F, 16V, Ceramic Disc	B1	C5	C-238-.1
C114	22pF, 1000V, Ceramic Disc	B3	C5	C-64-22p
C115	22pF, 1000V, Ceramic Disc	B3	C5	C-64-22p
C116	.1 μ F, 16V, Ceramic Disc	G3	E5	C-238-.1
C117	330 μ F, 160V, Aluminum Electrolytic	D2	E5	C-337-330
C118	330 μ F, 160V, Aluminum Electrolytic	C2	E5	C-337-330
C119	10 μ F, 25V, Aluminum Electrolytic	D3	F5	C-314-10
C120	10 μ F, 25V, Aluminum Electrolytic	D3	F6	C-314-10
C121	1000 μ F, 35V, Aluminum Electrolytic	C3	F6	C-309-1000
C122	1000 μ F, 35V, Aluminum Electrolytic	D3	F6	C-309-1000
C123	330pF, 500V, Ceramic Disc	F5	E3	C-22-330p
CR101	Rectifier Bridge (5A), PEO5	C4	G3	RF-48
CR102	Rectifier, 1N4006	C2	E4	RF-38
CR103	Rectifier, 1N4006	C2	E4	RF-38
CR104	Rectifier, 1N4006	C2	E4	RF-38
CR105	Rectifier, 1N4006	C2	E4	RF-38
CR106	Rectifier, 1N4006	C3	F5	RF-38
CR107	Rectifier, 1N4006	C3	F5	RF-38
CR108	Rectifier Bridge (1.5A), PF-40	C3	F5	RF-46
CR109	Rectifier, 1N4006	G5	E3	RF-38
CR110	Rectifier, 1N4006	G5	E3	RF-38
CR111	Rectifier, 1N4006	G5	E3	RF-38
CR112	Rectifier, 1N4006	G5	—	RF-38
F101	Fuse, 3/8 Amp, 250V, Slo-Blo	A4	H3	FU-18
F101	Fuse, 3/4 Amp, 250V, Slo-Blo	A4	H3	FU-19
F101	Fuse, 8/10 Amp, 250V, Slo-Blo	A4	H3	FU-52
F101	Fuse, 4/10 Amp, 250V, Slo-Blo	A4	H3	FU-53
J1001	Power Connector	A4	G2	CS-388
J1003	Cable Assembly (26-pin)	—	E5	CA-10-3
J1008	Socket 16-pin	H5	—	SO-65
P1004	500V, Connector Male	—	B3	CS-389-3
P1005	2 pin, Connector	A1,B1	G2	CS-288-2
P1006	3 pin, Molex Connector	H5	D2	CS-288-3
R101	18k, 5%, 1/4W, Composition	E4	D2	R-76-18k
R102	4.7k, 5%, 1/4W, Composition	F1	D3	R-76-4.7k
R103	220k, 5%, 1/4W, Composition	C4	F3	R-76-220k
R104	4.7k, 5% 1/4W, Composition	F2	E4	R-76-4.7k
R105	390 Ω , 5%, 1/4W, Composition	F1	E4	R-76-390
R106	220 Ω , 5%, 1/4W, Composition	G3	D4	R-76-220
R107	2.4k, 5%, 1/4W, Composition	G3	E4	R-76-2.4k
R108	220 Ω , 5%, 1/4W, Composition	G2	D5	R-76-220
R109	2.4k, 5%, 1/4W, Composition	G2	E5	R-76-2.4k
R110	220 Ω , 5%, 1/4W, Composition	G2	D5	R-76-220

Table 6-2. Mother Board D220-103, Parts List (Cont.)

Circuit Desig.	Description	Location		Keithley Part No.
		Sch.	Pcb.	
R111	2.4k, 5%, 1/4W, Composition	G2	E5	R-76-2.4k
R112	4.7k, 5%, 1/4W, Composition	H1	E5	R-76-4.7k
R113	220Ω, 5%, 1/4W, Composition	G1	E5	R-76-220
R114	Thick Film Resistor Network	E5	B5	TF-140
R115	4.7k, 5%, 1/4W, Composition	F3	C5	R-76-4.7k
R118	100k, ± 10%, 1/2W, Composition	D2	E5	R-1-100k
R119	100k, ± 10%, 1/2W, Composition	D2	E5	R-1-100k
R121	100Ω, ± 10%, 1/2W, Composition	G5	E3	R-1-100
R122	100Ω, ± 10%, 1/2W, Composition	G4	E3	R-1-100
R125	4.7k, 5%, 1/4W, Composition	E2	D4	R-76-4.7k
R126	10k, 5%, 1/4W, Composition	F1	D5	R-76-10k
R127	4.7k, 5%, 1/4W, Composition	G4	E3	R-76-4.7k
R128	47kΩ, 5%, 0.25W, Composition	G5	E3	R-76-47k
S101	Switch, Power	A3	B2	SW-426
S102	Switch, Line	A3	G2	SW-397
T101	Transformer	B2	F2	TR-186
T101	Transformer (special for 90V-110V 180V-220V operation)	B2	F2	TR-187
U101	1024 X 4-bit Static Ram, 2114	D5	C2	LSI-15
U102	Oscillator/Clock, 4060	E4	D2	IC-197
U103	1024 X 4-bit Static Ram, 2114	C5	C2	LSI-15
U104	Up/Down Counter, 74LS193	F4	D2	IC-214
U105	1024 X 4-bit Static Ram, 2114	D6	C2	LSI-15
U106	Quad 2-In. Nand Gate, 74LS00	SEV	D2	IC-163
U107	1024 X 4-bit Static Ram, 2114	SEV	C3	LSI-15
U108	Quad 2-In. NOR Gate, 74LS02	SEV	D3	IC-179
U109	Erasable Prom, 2732	B5	C3	230-800-**
U110	Decoder/Demultiplexer, 74LS138	F3	D3	IC-182
U111	Erasable Prom, 2732	A5	C4	230-801-**
U112	8-bit Shift Register, 14094	E1	D4	IC-251
U113	Quad Exclusive OR Gate, 7486	Sev	D4	IC-116
U114	Interface Adapter, SY6522	C2	C4	LSI-28
U115	Microprocessor, MC6808	B2	C5	LSI-27
U116	Bus Driver, 14503	E6	C5	IC-250
U117	Hex Inverter, 16-pin DIP, 4049	SEV	E5	IC-106
VR101	5 Volt Regulator, LM309K	D4	F4	IC-34
VR102	± 15V, 3-term, 7915	D3	F5	IC-174
VR103	3-term Positive Voltage Regulator, 7815	D3	F5	IC-96
W101	Jumper	B6	D2	J-3
W102	Jumper	B6	D2	J-3
Y101	4.0 MHZ Crystal	—	C5	CR-10

**Order same software as presently installed. For example, if B6 is displayed upon power up, order 230-800-B6 for U109 and 230-801-B6 for U111.

Table 6-3. Display Board D220—113, Parts List

Circuit Desig.	Description	Location		Keithley Part No.
		Sch.	Pcb.	
C201	10 μ F, 25V, Aluminum Electrolytic	D5	C3	C-314-10
DS201	± 1 , Digital Display	B1	B2	DD-31
DS202	"8" Digital Display	C1	B2	DD-30
DS203	"8" Digital Display	C1	C2	DD-30
DS204	"8" Digital Display	D1	C2	DD-30
DS205	"8" Digital Display	D1	D2	DD-30
DS206	± 1 , Digital Display	E1	D2	DD-31
DS207	"8" Digital Display	E1	E2	DD-30
DS208	Pilot Light	G3	E1	PL-67
DS209	Pilot Light	G2	E2	PL-67
DS210	Pilot Light	E2	E2	PL-67
DS211	Pilot Light	G3	B2	PL-67
DS212	Pilot Light	H3	B2	PL-67
DS213	Pilot Light	H3	C2	PL-67
DS214	Pilot Light	F3	D2	PL-67
DS215	Pilot Light	F3	D2	PL-67
DS216	Pilot Light	G3	E2	PL-67
DS217	Pilot Light	G3	E2	PL-67
DS218	Pilot Light	H3	C3	PL-67
DS219	Pilot Light	F3	D3	PL-67
P1002	Cable Assembly	A6	E4	CA-15-1
Q201	PNP Silicon Transistor, 2N4355	F5	E1	TG-90
Q202	PNP Silicon Transistor, 2N4355	H5	E1	TG-90
Q203	PNP Silicon Transistor, 2N4355	H5	E1	TG-90
Q204	PNP Silicon Transistor, 2N4355	H5	E1	TG-90
Q205	PNP Silicon Transistor, 2N4355	F5	E2	TG-90
Q206	PNP Silicon Transistor, 2N4355	G5	E2	TG-90
Q207	PNP Silicon Transistor, 2N4355	G5	E2	TG-90
Q208	PNP Silicon Transistor, 2N4355	G5	E2	TG-90
R201	Thick Film Resistor Network	SEV	D2	TF-165-1
R202	Thick Film Resistor Network	SEV	F1	TF-77
S201	Pushbutton Switch	A3	B2	SW-435
S202	Pushbutton Switch	B3	B2	SW-435
S203	Pushbutton Switch	B3	C2	SW-435
S204	Pushbutton Switch	A3	D2	SW-435
S205	Pushbutton Switch	A3	D2	SW-435
S206	Pushbutton Switch	B4	E2	SW-435
S207	Pushbutton Switch	B4	E2	SW-435
S208	Pushbutton Switch	A4	B3	SW-435
S209	Pushbutton Switch	A4	C3	SW-435
S210	Pushbutton Switch	B4	D3	SW-435
S211	Pushbutton Switch	B4	D3	SW-435
S212	Pushbutton Switch	A4	E3	SW-435
S213	Pushbutton Switch	A4	E3	SW-435
S214	Pushbutton Switch	B5	F2	SW-435
S215	Pushbutton Switch	B5	F2	SW-435
S216	Pushbutton Switch	A5	G2	SW-435
S217	Pushbutton Switch	A5	F2	SW-435
S218	Pushbutton Switch	A3	F2	SW-435
S219	Pushbutton Switch	B3	G2	SW-435
S220	Pushbutton Switch	B3	F3	SW-435
S221	Pushbutton Switch	A2	F3	SW-435
S222	Pushbutton Switch	A2	G3	SW-435
S223	Pushbutton Switch	B2	F3	SW-435
S224	Pushbutton Switch	B2	F3	SW-435
S225	Pushbutton Switch	A2	G3	SW-435
U201	MOS to LED Segment Driver, 75492	SEV	B3	IC-169
U202	MOS to LED Segment Driver, 75492	SEV	C3	IC-169
U203	8-bit Shift Register, 74LS164	C5	D3	IC-127
U204	MOS to LED Segement Driver, 75492	SEV	E3	IC-169

Table 6-4. Analog Board D230-123, Parts List

Circuit Desig.	Description	Location		Keithley Part No.
		Sch.	Pcb.	
C301	.01 μ F, 500V, Ceramic Disc	F5	C2	C-22-.01
C302	.47 μ F, 50V, Ceramic Film	B4	D2	C-237-.47
C303	.1 μ F, 16V, Ceramic Disc	E3	C2	C-238-.1
C304	.1 μ F, 16V, Ceramic Disc	E3	B2	C-238-.1
C305	.01 μ F, 500V, Ceramic Disc	B4	D2	C-22-.01
C307	0.1 μ F, 250V, Metalized Polyester	B4	E3	C-178-.1
C308	.01 μ F, 500V, Ceramic Disc	D3	F3	C-22-.01
C309	10 μ F, 25V, Aluminum Electrolytic	B6	D3	C-314-10
C310	10 μ F, 25V, Aluminum Electrolytic	C6	D3	C-314-10
C311	10 μ F, 25V, Aluminum Electrolytic	B6	E3	C-314-10
C312	4.7 μ F, 350V, Aluminum Electrolytic	D3	F4	C-240-4.7
C313	250 μ F, 25V, Aluminum Electrolytic	C4	E4	C-314-220
C315	.001 μ F, 500V, Ceramic Disc	C2	C4	C-22-.001
C316	.1 μ F, 16V, Ceramic Disc	C2	C4	C-238-.1
C317	.1 μ F, 16V, Ceramic Disc	F2	D4	C-238-.1
C318	.1 μ F, 16V, Ceramic Disc	C3	F4	C-238-.1
C319	470pF, 500V, Polystyrene	B3	C5	C-138-470p
C320	220pF, 500V, Metalized Polyester	B2	C5	C-22-220p
C321	.1 μ F, 16V, Ceramic Disc	C1	F5	C-238-.1
C322	.01 μ F, 500V, Ceramic Disc	H3	E5	C-22-.01
C324	.1 μ F, 16V, Ceramic Disc	F4	D5	C-238-.1
C325	4.7 μ F, 350V, Aluminum Electrolytic	D1	F5	C-240-4.7
C326	.01 μ F, 500V, Ceramic Disc	D1	F5	C-22-.01
C329	Capacitor, .01 μ F, 500V, Ceramic Disc			C-22-.01
C330	Capacitor, 1.5 μ F, 25V, Aluminum Electrolytic	C2	D2	C-314-1.5
CR301	Silicon Diode, 1N914	A4	D2	RF-28
CR302	Silicon Diode, 1N914	B4	E3	RF-28
CR303	Rectifier, 1N4006	C4	E4	RF-38
CR304	Rectifier, 1N3595	B3	C4	RF-43
CR305	Rectifier, 1N3595	G2	D4	RF-43
CR306	Silicon Diode, 1N914	D2	F4	RF-28
CR307	Rectifier, 1N3595	B3	C4	RF-43
CR308	Rectifier, 1N3595	F2	D4	RF-43
CR309	Rectifier, 1N3595	F3	D4	RF-43
CR310	Rectifier, 1N3595	G3	D5	RF-43
CR311	Rectifier, 1N3595	G4	D5	RF-43
CR312	Silicon Diode, 1N914	D2	F5	RF-28
CR313	Rectifier, 1N3595	F4	D5	RF-43
CR314	Rectifier, 1N3595	F4	D5	RF-43
CR315	Rectifier, 1N3595	G4	D5	RF-43
J1003	500V, Connector Male	B2	E5	CS-389-3
J1009	4 pin, Connector	H3	E5	CS-288-4
K301	Relay	SEV	D4	RL-60
K302	Relay	SEV	E4	RL-60
K303	Relay	SEV	E5	RL-71
Q301	N-Channel FET, 2N4392	F4	C3	TG-128
Q302	N-Channel FET, 2N4392	E4	D3	TG-128
Q303	N-Channel FET, 2N4392	E4	D3	TG-128
Q304	N-Channel FET, 2N4392	E4	C3	TG-128
Q305	N-Channel FET, 2N4392	E4	C3	TG-128
Q306	N-Channel FET, 2N4392	D4	D3	TG-128
Q307	N-Channel FET, 2N4392	D4	D3	TG-128
Q308	N-Channel FET, 2N4392	C2	C4	TG-130
Q309	PNP, Transistor, Silicon, 2N3906	C3	F4	TG-84
Q310	PNP, Transistor, Silicon, 2N3906	D3	G4	TG-84
Q311	Diode Current Unit, J505	C2	F4	TG-140
Q312	NPN, Silicon, 2N3904	C2	G5	TG-47
Q313	NPN, Silicon, 2N3904	E2	G5	TG-47
Q314	PNP, Transistor, MJ15012	D3	F4	230-600
Q315	NPN, Transistor, MJ15011	D1	F5	230-601

Table 6-4. Analog Board D230-123, Parts List

Circuit Desig.	Description	Location		Keithley Part No.
		Sch.	Pcb.	
R301	100k Pot	G5	C1	RP-97-100k
R302	100k Pot	G5	C2	RP-97-100k
R303	47k, 5%, .11W	E5	C2	TF-103-4
R304	47k, 5%, .11W	D5	D2	TF-103-3
R305	47k, 5%, .11W	D3	D2	TF-103-3
R306	10k, 5%, 1/4W, Composition	A4	D2	R-76-10k
R307	10k, 5%, 1/4W, Composition	A4	D2	R-76-10k
R308	10k, 5%, 1/4W, Composition	B3	D2	R-76-10k
R309	301k, 1%, 1/8W	F5	B2	R-88-301k
R310	301k, 1%, 1/8W	F5	C2	R-88-301k
R311	6.04k, 1%, 1/8W	F5	C2	R-88-6.04k
R312	2.2k, 5%, 1/4W, Composition	G3	D2	R-76-1k
R313	10k, 1%, 1/8W	G5	B2	R-88-10k
R314	1M, 1%, 0.12W, Metal Film	G5	B2	R-88-1M
R315	49.9k, 1%, 1/8W	G5	C2	R-88-49.9k
R316	22.2k, .1%, 1/10W, Metal Film	F4	C2	R-263-22.2k
R317	10k, 5%, 1/4W, Composition	B3	D2	R-76-10k
R318	4.7k, 5%, 1/4W, Composition	D5	D2	R-76-4.7k
R319	4.7k, 5%, 1/4W, Composition	D5	D2	R-76-4.7k
R320	200Ω, Pot	F4	C3	RP-97-200
R321	10k Pot	C4	B4	RP-97-10k
R322	22.2k, 1%, 1/10W, Metal Film	F4	C4	R-263-22.2k
R323	10k, 5%, 1/4W, Composition	B3	D4	R-76-10k
R324	11k, 1%, 1/8W	G4	C4	R-88-11k
R325	15k, 5%, 1/4W, Composition	A1	C4	R-76-15k
R326	24k, 5%, 1/4W, Composition	B2	C4	R-76-24k
R327	100k, 5%, 1/4W, Composition	B1	C4	R-76-100k
R328	24k, 5%, 1/4W, Composition	B1	C4	R-76-24k
R329	10k, 5%, 1/4W, Composition	B4	D4	R-76-10k
R330	3.3k, 5%, 1/4W, Composition	B1	C4	R-76-3.3k
R331	10k, 5%, 1/4W, Composition	A1	C4	R-76-10k
R332	100k, 5%, .11W	SEV	D4	TF-103-2
R333	5k Pot	B2	C4	RP-97-5k
R334	10k, .1%, 1/10W, Metal Film	D4	D4	R-263-10k
R335	2.2M, 5%, 1/4W, Composition	B4	E4	R-76-2.2M
R336	2.49k, 1%, 1/8W	B2	B4	R-88-2.49k
R337	2.49k, 1%, 1/8W	C2	B4	R-88-2.49k
R338	7.5k, .1%, 0.12W, Metal Film	C2	C4	R-88-7.5k
R339	100k, 5%, 1/4W, Composition	C4	D4	R-76-100k
R340	88.7k, .1%, 1/10W, Metal Film	D4	D4	R-263-88.7k
R341	10k, 5%, 1/4W, Composition	B2	C4	R-76-10k
R342	100Ω, Pot	F4	C4	RP-97-100
R343	10k Pot	E4	C4	RP-97-10k
R344	1k Pot	D4	D4	RP-97-1k
R345	47Ω, 10%, 1W, Composition	D4	D4	R-2-47
R346	19.98k, .1%, 1/10W, Metal Film	F3	F4	R-263-19.98k
R347	12.1Ω, 1%, 0.12W, Metal Film	F3	C4	R-88-12.1
R348	294Ω, 1%, 0.12W, Metal Film	E2	D4	R-88-294
R349	430Ω, 5%, 1/10W, Metal Film	E3	E4	R-76-430
R350	2.5k, 0.1%, 1/8W, Metal Film	C3	E4	R-176-2.5k
R351	101k, .1%, 1/20W, Metal Film	E4	F4	R-263-101k
R352	13Ω, 1%, 0.12W, Metal Film	F3	C4	R-88-13
R353	26.1Ω, 1%, 0.12W, Metal Film	F3	D4	R-88-26.1
R354	39Ω, 5%, 0.12W, Metal Film	E3	E4	R-76-39
R355	4.7k, 5%, 1/4W, Composition	C2	E4	R-76-4.7k
R356	996k, .1%, 1/4W, Metal Film	E4	F4	R-264-996k
R357	204.8k, .1%, 1/4W, Metal Film	B3	C4	R-264-204.8k
R358	13Ω, 1%, 0.12W, Metal Film	F1	C5	R-88-13
R359	26.1Ω, 1%, 0.12W, Metal Film	E1	D5	R-88-26.1
R360	39Ω, 5%, 1/4W, Composition	E1	E5	R-76-39
R361	1k, 5%, 1/4W, Composition	C3	E5	R-76-1k

Table 6-4. Analog Board D230-123, Parts List (Cont.)

Circuit Desig.	Description	Location		Keithley Part No.
		Sch.	Pcb.	
R358	13Ω, 1%, 0.12W, Metal Film	F1	C5	R-88-13
R359	26.1Ω, 1%, 0.12W, Metal Film	E1	D5	R-88-26.1
R360	62Ω, 5%, 1/4W, Composition	E1	E5	R-76-62
R361	1k, 5%, 1/4W, Composition	C3	E5	R-76-1k
R362	12.1Ω, 1%, 0.12W, Metal Film	F1	C5	R-88-12.1
R363	294Ω, 1%, 0.12W, Metal Film	E2	D5	R-88-294
R364	430Ω, 5%, 1/4W, Composition	E1	E5	R-76-430
R365	2.5k, 0.1%, 1/8W, Metal Film	C1	E5	R-176-2.5k
R366	100k, 0.1%, 1/8W, Metal Film	D2	C5	R-176-100k
R367	47Ω, 10%, 1W, Composition	D1	F5	R-1-22
R368	100k, 0.1%, 1/8W, Metal Film	D2	C5	R-176-100k
R369	100k, 0.1%, 1/8W, Metal Film	D2	C5	R-176-100k
R370	100k, 0.1%, 1/8W, Metal Film	D2	C5	R-176-100k
R371	100k, 0.1%, 1/8W, Metal Film	D2	C5	R-176-100k
R372	100k, 0.1%, 1/8W, Metal Film	D2	C5	R-176-100k
R373	2.5k, 0.1%, 1/8W, Metal Film	D2	C5	R-176-2.5k
R374	3.9k, 5%, 1/4W, Composition	C2	E4	R-76-3.9k
R375	10M, 5%, 1/4W, Composition	E4	D3	R-76-10M
R376	10M, 5%, 1/4W, Composition	F4	D3	R-76-10M
U301	8-bit Register, 14094	C4	C1	IC-251
U302	8-bit Register, 14094	C3	D1	IC-251
U303	8-bit shift Register, 14094	C2	D1	IC-251
U304	Quad 2-Input AND, 4081	SEV	E2	IC-138
U305	Integrated Circuit D/A Converter, DAC80-CBI-V	E4	C2	IC-323
U306	Operational Amplifier, AD3247	F4	D2	IC-248
U307	Quad Monolithic SPST CMOS Analog Switch, LM317T	SEV	D2	IC-320
U308	Quad 2-Input NAND, 4011	SEV	E2	IC-102
U309	Operational Amplifier, AD3247	C4	C3	IC-248
U310	Decoder/Demultiplexer, 14555	SEV	D3	IC-312
U311	Hex Inverter, 16-pin, 4049	SEV	E3	IC-106
U312	Quad Comparator, LM339	B1	C3	IC-219
U313	Quad Comparator, LM339	SEV	D3	IC-219
U314	High/Voltage, High/Current Transistor Array, VLN2003A	B5	D3	IC-206
U315	Op Amp, AD544k	B2	C4	IC-274
U316	Op Amp, LF351N	D2	C5	IC-176
VR301	+5V Regulator, 7805	B6	E3	IC-93

Table 6-5. IEEE Interface Board D220-133, Parts List

Circuit Desig.	Description	Location		Keithley Part No.
		Sch.	Pcb.	
C401	.01 μ F, 500V, Ceramic Disc	H3	E2	C-22-.01
C402	.01 μ F, 500V, Ceramic Disc	F1	C3	C-22-.01
C403	10 μ F, 25V, Aluminum Electrolytic	F1	C3	C-314-10
CR401	Rectifier Bridge (1.5A), W04M	B4	E1	RF-46
CR402	Rectifier Bridge (1.5A), W04M	A4	E1	RF-46
J1017	IEEE Bus Connector	H2	F2	CS-443
	Hardware kit for J1017			CS-380
P1004	Cable Assembly	C1	C2	CA-10-2
Q401	NPN, Silicon Transistor, 2N3904	C5	C2	TG-47
R401	4.7k, 5%, 1/4W, Composition	D2	C1	R-76-4.7k
R402	4.7k, 5%, 1/4W, Composition	C5	C1	R-76-4.7k
R403	Thick Film Resistor Network	C4	D1	TF-102-10k
R404	Thick Film Resistor Network	B4	D1	TF-103-2
R405	100 Ω , 10%, 1/2W, Composition	A5	E1	R-1-100
R406	100 Ω , 10%, 1/2W, Composition	B5	E1	R-1-100
R407	100 Ω , 10%, 1/2W, Composition	A5	E1	R-1-100
R408	100 Ω , 10%, 1/2W, Composition	B5	E1	R-1-100
R409	Thick Film Resistor Network	F5	E2	TF-100
R410	Thick Film Resistor Network	SEV	E2	TF-103-1
R411	Resistor, 33 Ω , 10%, 1W, Composition			R-2-33
S401	Primary Address Switch	G5	E2	SW-450-5
U401	8-bit Shift Register, 4094	C2	D2	IC-251
U402	Shift Register, 4021	C3	D2	IC-130
U403	Hex Inverter, 74LS04	SEV	D2	IC-186
U404	GPIB Adapter, 59914	F3	D2	LSI-49
U405	Interface Bus Transceiver, SN75160	G2	E2	IC-298
U406	Decoder/Demultiplexer, 74LS138	E4	D3	IC-182
U407	Hex 3-state Buffer, 74LS367	F4	D3	IC-161
U408	Interface Bus Transceiver, 75161	G3	E3	IC-299
U409	Quad 2-Input Nand Gate, LS00	SEV	D2	IC-163
	Insulator			27493-25

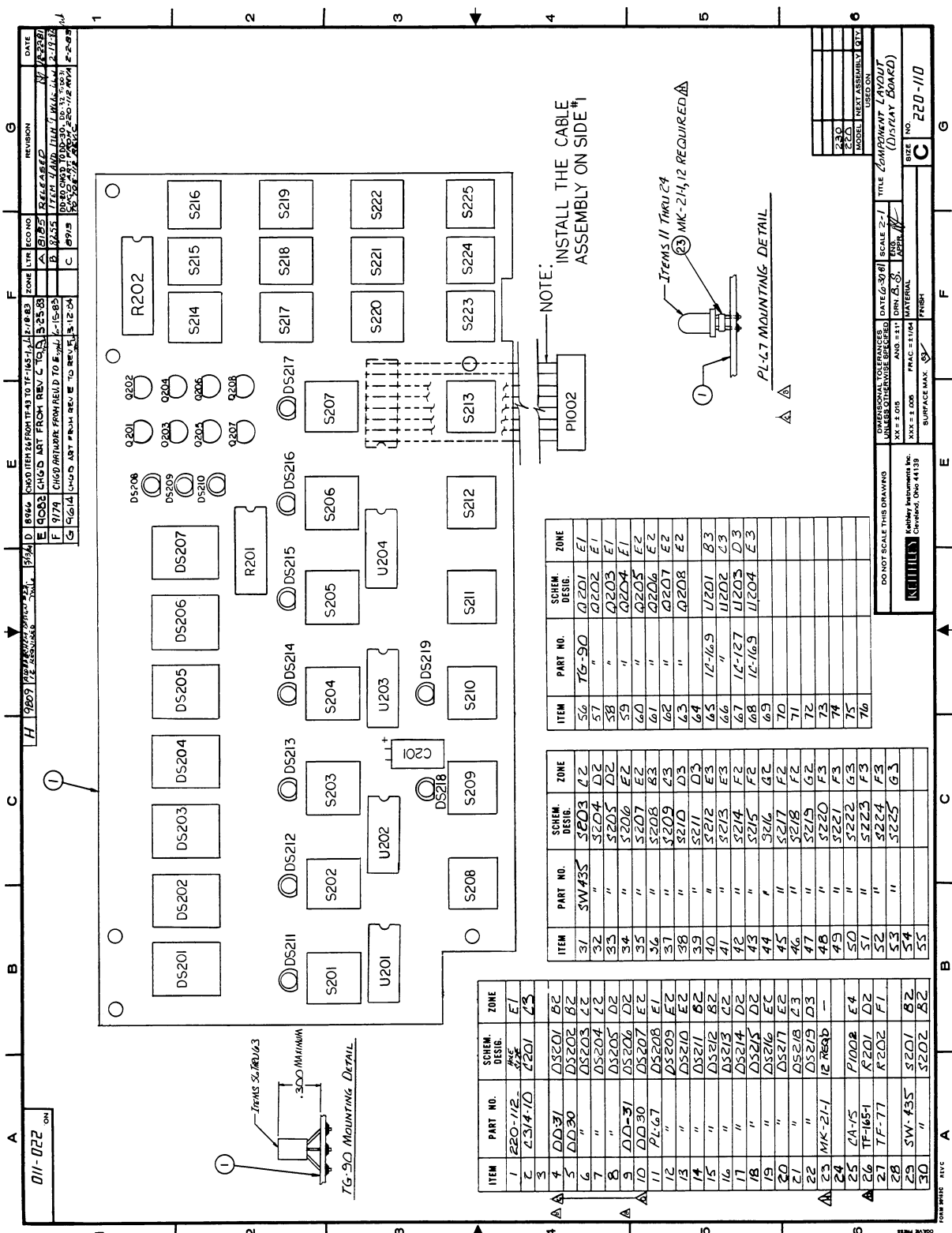

ITEM	PART NO.	SCHEM. DESIG.	ZONE
1	220-112	DS201	E1
2	2314-10	R201	E1
3			
4	DD-31	DS202	E2
5	DD-30	DS203	E2
6	"	DS204	E2
7	"	DS205	E2
8	"	DS206	E2
9	DD-31	DS207	E2
10	DD-30	DS208	E1
11	PL-67	DS209	E2
12	"	DS210	E2
13	"	DS211	E2
14	"	DS212	E2
15	"	DS213	E2
16	"	DS214	E2
17	"	DS215	E2
18	"	DS216	E2
19	"	DS217	E2
20	"	DS218	E3
21	"	DS219	E3
22	MK-211	IE READ	-
23	LA-15	F1002	E4
24	TF-165-1	R201	E2
25	TF-77	R202	F1
26	SW-435	S201	E2
27	"	S202	E2
28	"	S203	E2
29	"	S204	E2
30	"	S205	E2
31	"	S206	E2
32	"	S207	E2
33	"	S208	E2
34	"	S209	E2
35	"	S210	E2
36	"	S211	E2
37	"	S212	E2
38	"	S213	E2
39	"	S214	E2
40	"	S215	E2
41	"	S216	E2
42	"	S217	E2
43	"	S218	E2
44	"	S219	E2
45	"	S220	E2
46	"	S221	E2
47	"	S222	E2
48	"	S223	E2
49	"	S224	E2
50	"	S225	E2
51	"	U201	E2
52	"	U202	E2
53	"	U203	E2
54	"	U204	E2
55	"	P1002	E2

ITEM	PART NO.	SCHEM. DESIG.	ZONE
56	TF-90	DS201	E1
57	"	DS202	E1
58	"	DS203	E1
59	"	DS204	E1
60	"	DS205	E2
61	"	DS206	E2
62	"	DS207	E2
63	"	DS208	E2
64	"	U201	E3
65	12-16-9	U202	E3
66	"	U203	E3
67	12-127	U204	E3
68	12-16-5	U204	E3
69	"		
70	"		
71	"		
72	"		
73	"		
74	"		
75	"		
76	"		

DATE	NO.	REVISED
17/12/87	1	RELEASED
17/12/87	2	17TH JANUARY 1988
17/12/87	3	17TH JANUARY 1988
17/12/87	4	17TH JANUARY 1988
17/12/87	5	17TH JANUARY 1988
17/12/87	6	17TH JANUARY 1988
17/12/87	7	17TH JANUARY 1988
17/12/87	8	17TH JANUARY 1988
17/12/87	9	17TH JANUARY 1988
17/12/87	10	17TH JANUARY 1988
17/12/87	11	17TH JANUARY 1988
17/12/87	12	17TH JANUARY 1988
17/12/87	13	17TH JANUARY 1988
17/12/87	14	17TH JANUARY 1988
17/12/87	15	17TH JANUARY 1988
17/12/87	16	17TH JANUARY 1988
17/12/87	17	17TH JANUARY 1988
17/12/87	18	17TH JANUARY 1988
17/12/87	19	17TH JANUARY 1988
17/12/87	20	17TH JANUARY 1988
17/12/87	21	17TH JANUARY 1988
17/12/87	22	17TH JANUARY 1988
17/12/87	23	17TH JANUARY 1988
17/12/87	24	17TH JANUARY 1988
17/12/87	25	17TH JANUARY 1988
17/12/87	26	17TH JANUARY 1988
17/12/87	27	17TH JANUARY 1988
17/12/87	28	17TH JANUARY 1988
17/12/87	29	17TH JANUARY 1988
17/12/87	30	17TH JANUARY 1988

Figure 6-3. Display Board, Component Location Drawing, Dwg. No. 220-110

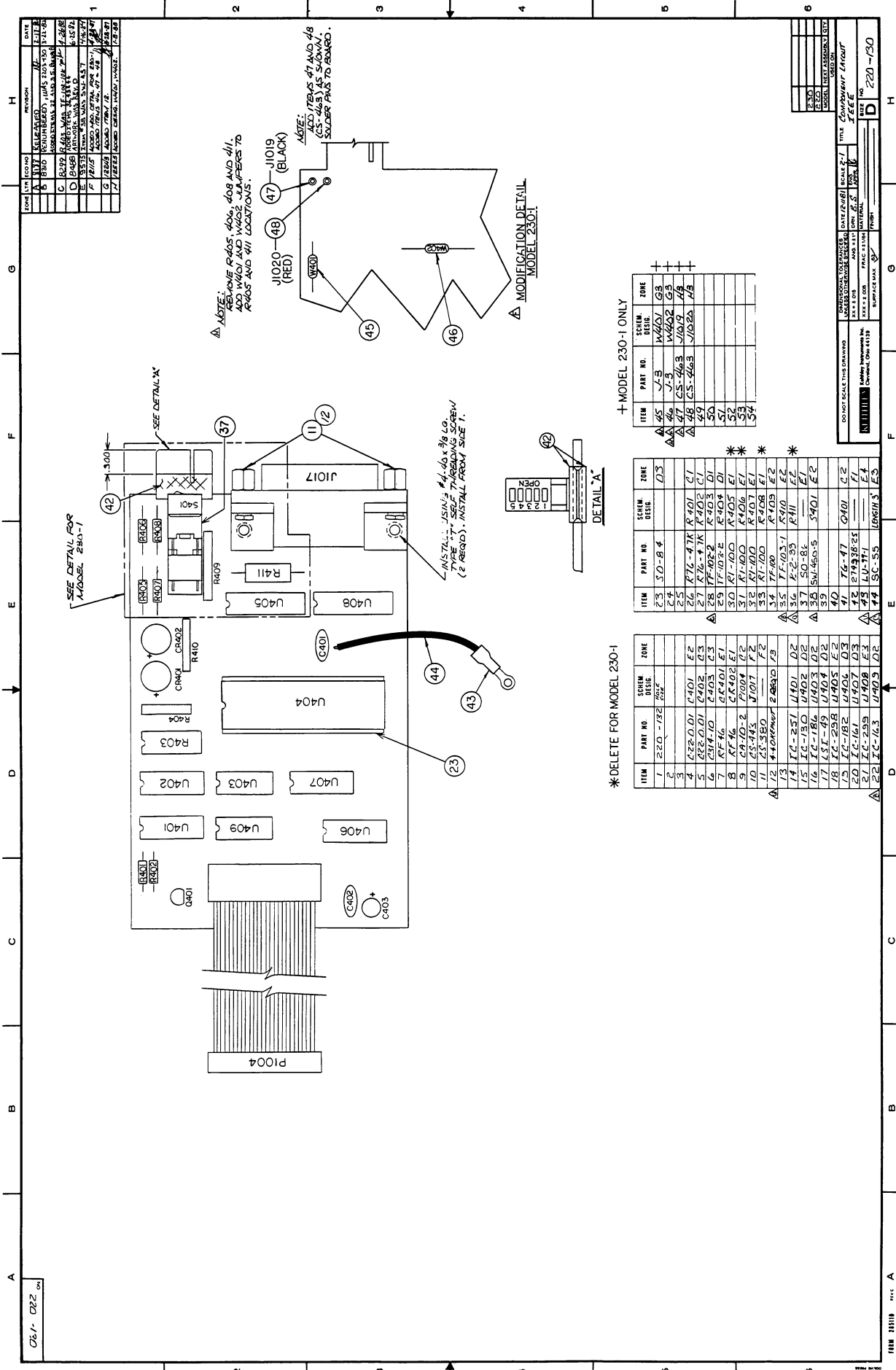

Figure 6-6. IEEE Interface Board, Component Location Drawing, Dwg. No. 220-130